

SPECIFICATIONS
FOR
“IHI” MODEL CCH2000
FULLY HYDRAULIC CRAWLER CRANE

IHI

IHI Construction Machinery Limited

TOKYO, JAPAN

1. GENERAL

This specification covers the Standard Specifications for IHI Model CCH2000 crawler crane.

2. OUTLINE

CCH2000 is of a Crawler Mounted Crane equipped with a latticed type tubular boom, that has been developed for Lift Crane work. This crane consists of the crawler undercarriage, the slewing superstructure and the crane boom in main construction. CCH2000 is powered by the diesel engine installed on the slewing superstructure as it's power source, and the power is transferred through the fully hydraulic drive/control system.

3. MAIN UNIT SPECIFICATION

(1) Dimensions

Overall crawler crane width:	7,770 mm
Overall crawler width:	7,770 mm
Crawler width center to center:	6,700 mm
Crawler shoe width:	1,070 mm
Overall crawler length:	9,160 mm
Rear end slewing radius:	6,000 mm
Boom foot pin height from ground level:	2,655 mm
Boom foot pin distance from slewing center:	1,600 mm
Rear end ground clearance:	1,630 mm
Min. ground clearance:	470 mm
Overall cab width (when on transportation):	3,200 mm
A-frame height (extended/sheave O.D.):	8,959 mm
A-frame ground clearance (folded/sheave O.D.):	3,775 mm

(2) Main Specifications

Slewing speed:	1.5min ⁻¹
Travel speed:	0.9/0.6 km/hr
Grade ability:	30% (16.7 °)

Engine

Manufacturer:	Cummins Inc.
Model:	QSL
Emission Certification:	U.S.EPA Tier3,CARB Tier3,EU Stare A
Type:	4-cycle, water-cooled, turbocharged and air cooled
Rated output:	242kW / 2,000min ⁻¹ (325HP / 2,000rpm)
Total displacement:	8.9L
Fuel tank capacity:	510L
Battery:	12V × 120AH × 2 pcs.

Hoisting Winch System (Main Hoist, Auxiliary Hoist)

Special specifications as for the free fall

Hydraulic motor:	Axial piston type
Reduction gear:	Two-stage planetary gear(drum in type)
Hoist drum:	Individual drums. Main/Auxiliary drum in same width, with lebus type groove.
Brake:	Wet type multi disc
Drum locks:	Ratchet type

Boom Hoisting Winch System

Hydraulic motor:	Axial piston type
Reduction gear:	Three-stage planetary gear(drum in type)
Hoist drum:	Dual drum, with Lebus type groove
Brake:	Wet type multi disc
Drum lock:	Ratchet type

3rd Hoisting Winch System (Special specifications)

Hydraulic motor:	Axial piston type
Reduction gear:	Two-stage planetary gear(drum in type)
Hoist drum:	Drum with Lebus type groove
Brake:	Wet type multi disc
Drum lock:	Ratchet type

Slewing

Hydraulic motor:	Axial piston type (Double)
Reduction gear:	One-stage planetary gear + spur gear (Double)
Slewing bearing:	Single row ball bearing type
Brake:	Wet type multi disc
Swing lock:	Pin type

Traction

Hydraulic motor:	Axial piston type with brake valve
Reduction gear:	3-stage planetary gear, shoe-in type
Crawler shoe:	Semi-open type
Parking brake:	Wet type multi disc

Main Pump

Axial piston pump:	3pcs.
--------------------	-------

Control Pump

Gear pump:	2 pcs.
------------	--------

Cylinder circuit Pump

Gear pump:	1 pc.
------------	-------

4. MAIN STRUCTURE

(1) Power Driving System

The hydraulic pumps are driven directly by a diesel engine installed on the rear right side part of the slewing superstructure.

Three variable-displacement piston pumps are installed to actuate load hoisting, traction and provided for slewing and boom hoisting motors.

Three gear pumps are control circuit and auxiliary use.

Full power control system is introduced in circuit between three variable-displacement piston pumps, so as to utilize the engine output efficiently.

Fine speed control system is incorporated as standard-equipped in the variable-displacement pump to set a stepless regulation from the minimum to the maximum of pump displacement. With the speed control lever being manipulated, any required operational speed can be obtained from delicate inching operational speed to the maximum speed.

(2) Hoisting Winch System

The main and auxiliary drums are installed independently, and each driven by separate hydraulic motor through reduction gears which was had built-in by a drum respectively to hoist and lower the hook. Rope speed can be adjusting and controlled steplessly as winch speed control volume and per change of the stroke of control lever. Fine speed control system is standard equipped for positive inching operation.

The main and auxiliary winch lowering is made by power, and safety braking is ensured by the automatic braking.

Ratchet type drum locks are provided with both main and auxiliary hoist drum.

(3) Boom Hoisting Winch System

Boom hoist drum is driven by the independent hydraulic motor through reduction gear to permit the independent boom hoisting operation apart from the other operational movements.

Rope speed can be adjusted and controlled steplessly as winch speed control volume and per change of the stroke of control lever.

Boom lowering is made by power, and safety braking is ensured by the automatic braking and the ratchet type drum lock.

(4) Slewing System

Superstructure is slew by hydraulic motor through reduction gear independently from other operations, and is supported by the slewing base of a ball single row type which ensures smooth acceleration and stop of the slewing without causing oscillation of the suspended load.

The slewing parking brake and swing lock are equipped for safety during crane is in cease operation or in traveling.

(5) Traction System

Traction force is generated by two hydraulic motors through reduction units which are installed on both crawlers. Pivot-turn and spin-turn is easily operated.

Traction brake is of self-pressurized hydraulic brake which is automatically engaged with the control levers being at the neutral position.

Reduction unit and hydraulic motor is housed within the shoe width, which permits smooth traction available on uneven ground. The crawler shoe belt tightening adjustment is very easy with grease cylinder.

(6) Control Lever

The remote control valve is incorporated in circuit of the control lever for hoisting, boom hoisting, slewing and traction to actuate the main control valve for light touch sensitive control without operator's fatigue. Combined simultaneous operation is possible for the four movements of main and auxiliary hoisting/lowering, boom hoisting/lowering and slewing.

Automatic locking device provided, which prevent any trouble from miss-engagement by touch of control lever when operator get off and on from operator's room.

(7) Operator's Cab

The operator's cab is positioned on the front-right hand side of the superstructure, and is completely independent from the machine room for quiet operation.

The cab is designed to meet with ISO standard, having cab construction of 940 mm in width and of inner linings.

The windows are provided with 5 sides of front, rear, right, left and ceiling of the cab.

The right and left windows are of sliding type. The door is of a sliding type.

(8) OK Monitor

OK Monitor is provided on the instrument panel in the cab for centralized monitoring of machine operating conditions at a glance without leaving the operator's seat.

(9) Boom

Boom is made of high-tensile steel tube, with 18m basic boom in length (9m inner and 9m outer boom).

Standard boom can be extended upto 72m in maximum length by jointing 3m, 6m and 9m insert boom sections.

Light boom can be extended from 72m upto 93m in maximum length by jointing taper insert boom and 3m, 6m TW-insert jib boom and TW-outer jib boom sections.

Auxiliary jib, and 13m to 37m jib can be equipped with crane boom. Joint for boom and jib is of a pin joint type.

Pendant rope is of a single lock type for easier handling on assembling and disassembling of boom.

5. CRANE SPECIFICATION

(1) Specifications

Maximum lifting capacity × working radius:	200 ton × 5.2 m
Standard boom length:	18 m ~ 72 m
Light boom length:	72 m ~ 93 m
Maximum boom length with Jib boom:	109 m(72 m standard boom + 37 m jib boom)

Rope speed

hoisting/lowering:	120 m/min
Boom hoisting/lowering:	34 m/min × 2

Note: The value marked with “ ” will be changed according to the loads given.

Rope part lines

200t / 12t combination hock:	16 part lines / 12 part lines
13.5t hook:	1 part line
Boom hoist:	20 part lines

Standard counterweight:	92.0 ton
Carbody weight:	19.0 ton

Crane total weight:	Approx. 210 ton (with 18 m boom)
Average ground bearing pressure:	113 kPa (1.15 kgf/cm ²)

(2) Boom And Jib Combination

Jib Length (m)	Standard boom length (m)																		
	18	21	24	27	30	33	36	39	42	45	48	51	54	57	60	63	66	69	72
Aux.	⊙	⊙	⊙	⊙	⊙	⊙	⊙	⊙	⊙	⊙	⊙	⊙	⊙	⊙	⊙	⊙	⊙	⊙	⊙
13										⊙	⊙	⊙	⊙	⊙	⊙	⊙	⊙	⊙	⊙
19										⊙	⊙	⊙	⊙	⊙	⊙	⊙	⊙	⊙	⊙
25										⊙	⊙	⊙	⊙	⊙	⊙	⊙	⊙	⊙	⊙
31										⊙	⊙	⊙	⊙	⊙	⊙	⊙	⊙	⊙	⊙
37										⊙	⊙	⊙	⊙	⊙	⊙	⊙	⊙	⊙	⊙

Jib Length (m)	Light boom length (m)							
	72	75	78	81	84	87	90	93
Aux.	⊙	⊙	⊙	⊙	⊙	⊙	⊙	

(3) Wire Rope

Purpose	Rope dia (mm)	Breaking Strength(kN)	Rope Type
Load hoisting	φ 28	688	P·S(19)+39×P·7
Boom hoisting	φ 22.4	356	IWRC 6×WS(31)
Boom suspension	φ 40	1360	IWRC 6×P·WS(36)
Jib load hoisting	φ 28	688	P·S(19)+39×P·7
Jib boom suspension	φ 28	585	IWRC 6×Fi(29)
Jib strut suspension	φ 34	1020	IWRC 6×P·WS(36)

(4) Attachment Arrangement

As for the case with two kinds of mentions, the combination of the upper section is recommended boom constitution.

Crane boom arrangement

(O mark: Normal guide roller position ☆ mark: Special specifications guide post position)

Boom length	Standard boom arrangement (Crane Specifications)	Boom length	Standard boom arrangement (Crane Specifications)
18m		48m	
21m		51m	
24m		54m	
27m		57m	
30m		60m	
33m		63m	
36m		66m	
39m		69m	
42m		72m	
45m			

Boom length	Light boom arrangement (Crane Specifications)
72m	
75m	
78m	
81m	
84m	
87m	
90m	
93m	

Crane jib arrangement

(impossible of the equipment for a light boom)

Jib length	Jib arrangement
13m	
19m	
25m	
31m	
37m	

(5) General Dimensions

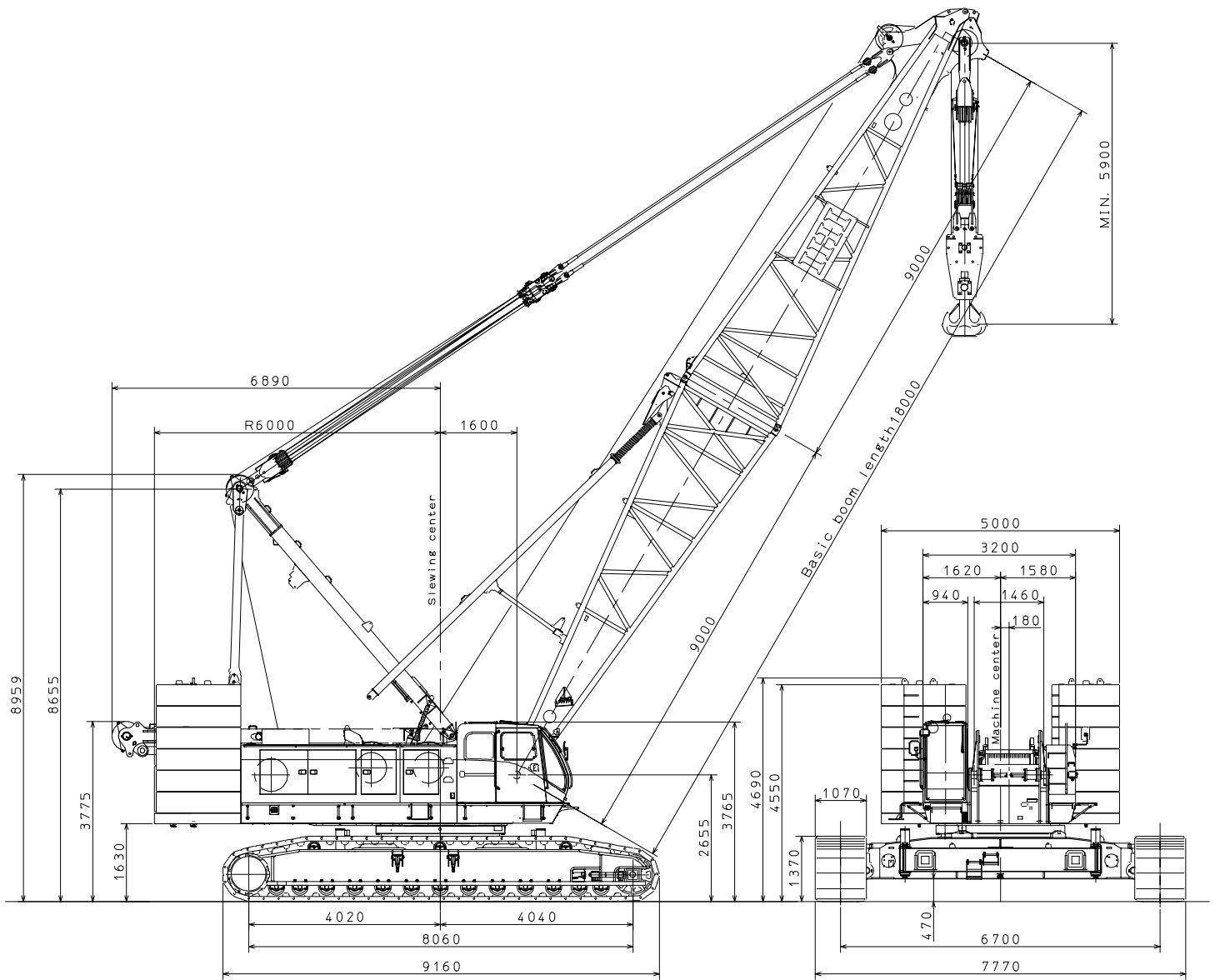

(6) Working Ranges Diagram

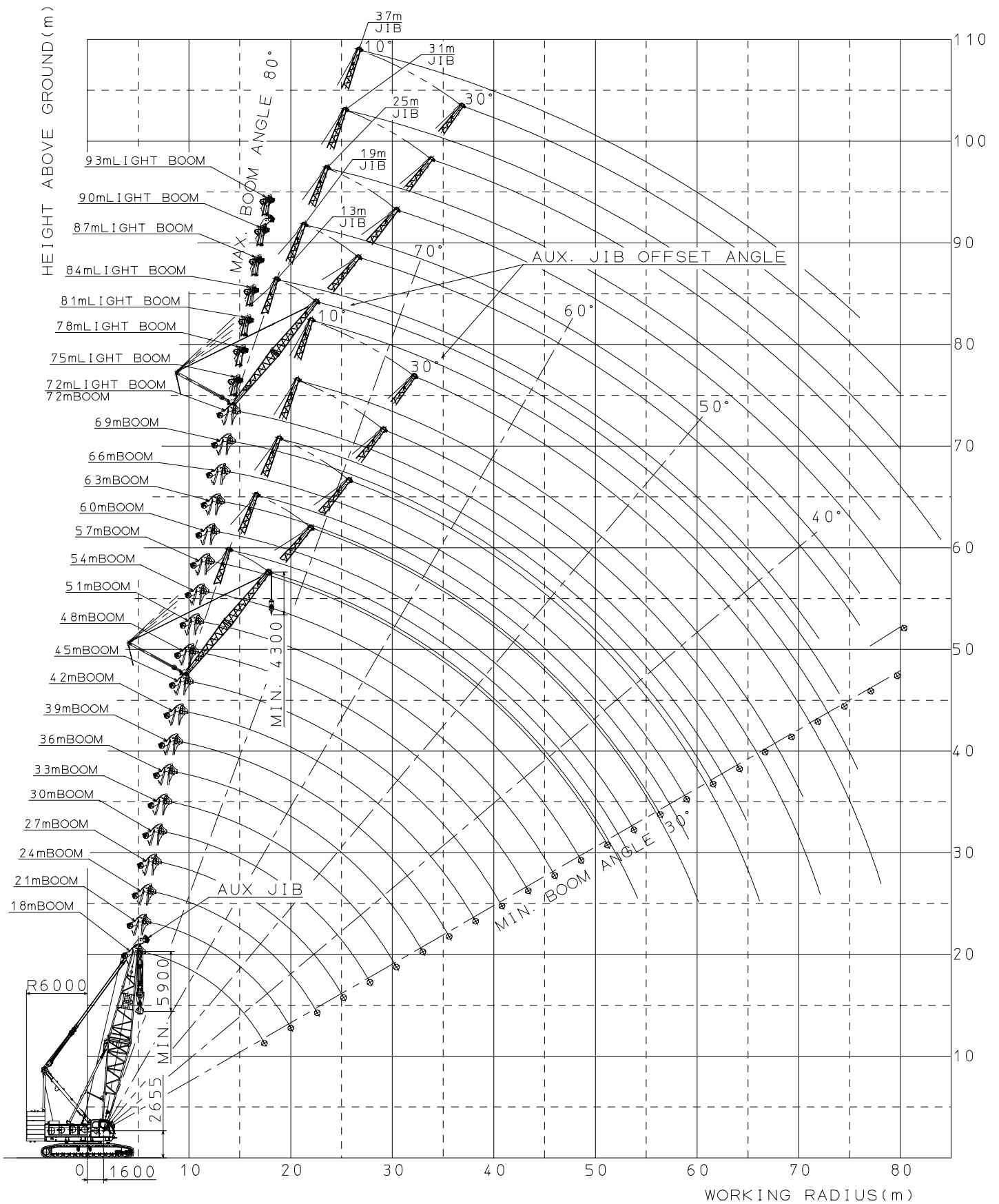

(7) CRAWLER CRANE RATED LIFTING LOADS

STANDARD BOOM RATED LIFTING LOADS(92.0t Counterweight + 19.0t Carbody weight)

unit : ton

Boom length(m)	18.0		21.0		24.0		27.0		30.0		33.0		36.0		39.0		42.0	
Working radius(m)	Load	Angle	Load	Angle	Load	Angle	Load	Angle	Load	Angle	Load	Angle	Load	Angle	Load	Angle	Load	Angle
5.0	5.2m×200	80.0	5.7m×175.0	80.0														
6.0	191.3	77.3	175.0	79.2	6.2m×150.0	80.0	6.7m×150.0	80.0										
7.0	164.3	74.0	163.8	76.4	150.0	78.1	150.0	79.4	7.3m×137.0	80.0	7.8m×125.0	80.0						
8.0	144.6	70.6	144.2	73.5	143.8	75.6	143.6	77.3	137.0	78.6	125.0	79.6	8.3m×112.5	80.0	8.8m×100.0	80.0		
9.0	129.1	67.2	128.7	70.6	128.3	73.1	128.1	75.1	125.0	76.6	125.0	77.8	112.5	78.9	100.0	79.7	9.3m×100.0	80.0
10.0	116.6	63.7	116.1	67.7	115.8	70.6	115.5	72.9	115.1	74.6	115.0	76.1	105.0	77.2	100.0	78.2	100.0	79.1
12.0	93.9	56.2	93.8	61.6	92.6	65.4	92.3	68.3	92.0	70.6	91.7	72.4	91.6	73.9	91.2	75.2	90.9	76.3
14.0	75.7	47.9	75.4	55.1	75.2	60.0	75.1	63.6	74.3	66.5	74.1	68.7	74.0	70.6	73.8	72.1	73.6	73.5
16.0	63.2	38.4	62.9	48.0	62.7	54.2	62.5	58.8	61.7	62.2	61.6	64.9	61.4	67.2	61.2	69.0	61.0	70.6
18.0	17.4m×55.2	30.0	54.1	39.9	53.8	48.0	53.4	53.6	52.6	57.7	52.4	61.0	52.3	63.6	52.0	65.8	51.8	67.6
20.0			47.2	30.0	46.9	41.1	46.7	48.0	45.7	53.1	45.5	56.9	45.4	60.0	45.1	62.5	44.9	64.6
22.0					41.4	32.9	41.2	41.9	40.4	48.0	40.1	52.6	39.9	56.2	39.6	59.1	39.4	61.6
24.0					22.6m×39.8	30.0	36.2	34.9	36.0	42.6	35.9	48.1	35.5	52.3	35.3	55.6	35.0	58.4
26.0							25.2m×33.9	30.0	32.4	36.5	32.2	43.1	32.1	48.1	31.6	51.9	31.4	55.1
28.0									27.8m×29.6	30.0	29.2	37.7	29.1	43.6	28.8	48.1	28.4	51.7
30.0											26.6	31.4	26.5	38.7	26.2	43.9	26.0	48.1
32.0											30.4m×26.1	30.0	24.2	33.1	24.0	39.5	23.8	44.3
34.0													33.0m×23.0	30.0	22.0	34.5	21.9	40.1
36.0															35.6m×20.4	30.0	20.1	35.6
38.0																	18.6	30.6
40.0																	38.2m×18.5	30.0
No. of Part line	16		14		12		12		11		10		9		8		8	

Note:

1.THE VALUES OF RATED LOAD GIVEN IN THIS TABLE ARE THE LOAD OF WITHIN 78% OF TIPPING LOAD

AND WITH THE FORWARD STABILITY OF 1.15 OR HIGHER FOR FULL SWINGING OF 360 DEGREES ON A FIRM LEVEL GROUND.

2.THE FIGURE ENCLOSED WITHIN BOLD LINES IN THIS TABLE ARE THE VALUES DETERMINED BASED ON THE STRENGTH OF THE BOOM,ETC.

3.THE WORKING RADIUS REFERS TO THE HORIZONTAL DISTANCE FROM THE CENTER OF SWINGING TO THE HOOK AXIS.

4.FOR THE OPERATION, BE SURE TO RAISE THE A-FRAME.

5.THE LENGTH OF THE JIB WHICH CAN BE MOUNTED TO THE BOOM IS AS SHOWN BELOW:

Jib length(m)	Aux. Jib	13	19	25	31	37
Boom length(m)	18~72	45~72	45~72	45~72	45~72	45~72

6.THE ACTUAL LIFTING LOAD IS OBTAINED BY SUBTRACTING THE MASS OF ALL LIFTING EQUIPMENT

SUCH AS THE MAIN HOOK,AUX. HOOK,ETC. FROM THE VALUES GIVEN IN THIS TABLE.

200t Hook...3.0t 90t Hook...1.6t 35t Hook...1.1t

125t Hook...2.4t 60t Hook...1.4t 13.5t Hook...0.6t

7.WHEN THE JIB IS MOUNTED, THE RATED LOAD WITH THE MAIN HOOK IS OBTAINED

BY SUBTRACTING THE VALUE AS SHOWN BELOW (INCLUDING THE MASS OF THE AUX. HOOK) FROM THE VALUES GIVEN IN THIS TABLE.

Jib length(m)	Aux. Jib	13	19	25	31	37
Subtraction mass (t)	0.8	3.5	4.0	4.9	6.0	6.7

8.THE RATED LOAD OF THE AUX. JIB IS OBTAINED BY SUBTRACTING 0.4t

FROM THE VALUES GIVEN IN THIS TABLE CORRESPONDING TO THE LENGTH OF THE MOUNTED BOOM.

BUT THE MAX. RATED LOAD IS 13.5ton.

THE RATED LOAD WITH THE JIB OF 13.0m TO 37.0m LONG REFERS TO THE JIB RATED LOAD TABLE.

9.WHEN THE MAIN HOOK IS MOUNTED THE LOAD WHICH CAN BE LIFTED

WITH THE JIB IS GIVEN BY SUBTRACTING THE TOTAL MASS OF MAIN AND AUX. HOOKS FROM THE VALUE IN THIS TABLE.

10.THE RATED LOAD ARE LIMITED ACCORDING TO THE WIRE ROPE PART LINE AS SHOWN BELOW:

1 PART OF LINE ... UP TO 13.5 ton	5 PART OF LINE ... UP TO 62.5ton	9 PART OF LINE ... UP TO 112.5ton	13 PART OF LINE ... UP TO 162.5ton
2 PART OF LINE ... UP TO 25.0ton	6 PART OF LINE ... UP TO 75.0ton	10 PART OF LINE ... UP TO 125.0ton	14 PART OF LINE ... UP TO 175.0ton
3 PART OF LINE ... UP TO 37.5ton	7 PART OF LINE ... UP TO 87.5ton	11 PART OF LINE ... UP TO 137.5ton	15 PART OF LINE ... UP TO 187.5ton
4 PART OF LINE ... UP TO 50.0ton	8 PART OF LINE ... UP TO 100.0ton	12 PART OF LINE ... UP TO 150.0ton	16 PART OF LINE ... UP TO 200.0ton

STANDARD BOOM RATED LIFTING LOADS(92.0t Counterweight + 19.0t Carbody weight)

unit: ton

Boom length(m)	45.0		48.0		51.0		54.0		57.0		60.0		63.0		66.0		69.0		72.0	
	Load	Angle	Load	Angle	Load	Angle	Load	Angle	Load	Angle	Load	Angle	Load	Angle	Load	Angle	Load	Angle	Load	Angle
5.0																				
6.0																				
7.0																				
8.0																				
9.0	9.9m× 87.5	80.0																		
10.0	87.5	79.8	10.4m× 82.0	80.0	10.9m× 75.0	80.0	11.4m× 75.0	80.0												
12.0	87.5	77.2	78.0	78.0	75.0	78.8	75.0	79.4	62.5	80.0	12.5m× 62.5	80.0	13.0m× 56.0	80.0	13.5m× 50.0	80.0				
14.0	73.5	74.6	71.1	75.6	71.0	76.4	68.6	77.2	62.0	77.9	60.0	78.5	56.0	79.1	50.0	79.6	47.5	80.0	14.6m× 42.0	80.0
16.0	60.9	71.9	60.6	73.1	60.5	74.1	60.2	75.0	60.0	75.8	56.2	76.6	52.7	77.2	50.0	77.8	45.3	78.3	42.0	78.8
18.0	51.7	69.2	51.5	70.6	51.3	71.8	51.0	72.8	50.9	73.7	50.6	74.6	48.9	75.3	48.4	76.0	43.5	76.6	41.0	77.2
20.0	44.7	66.5	44.5	68.0	44.3	69.4	44.1	70.6	43.9	71.6	43.7	72.6	43.5	73.4	43.3	74.2	41.8	74.9	38.6	75.6
22.0	39.2	63.6	39.0	65.4	38.8	66.9	38.6	68.3	38.4	69.5	38.2	70.6	38.0	71.5	37.8	72.4	37.6	73.2	35.5	73.9
24.0	34.9	60.7	34.6	62.7	34.4	64.5	34.2	66.0	34.0	67.3	33.8	68.5	33.6	69.6	33.3	70.6	33.1	71.4	32.8	72.2
26.0	31.2	57.8	31.0	60.0	30.8	61.9	30.5	63.6	30.4	65.1	30.1	66.4	29.9	67.6	29.7	68.7	29.5	69.7	29.3	70.6
28.0	28.2	54.7	28.0	57.2	27.7	59.3	27.5	61.2	27.3	62.9	27.1	64.3	26.9	65.6	26.7	66.8	26.4	67.9	26.3	68.9
30.0	25.8	51.5	25.4	54.3	25.2	56.7	25.0	58.8	24.7	60.6	24.5	62.2	24.3	63.6	24.0	64.9	23.8	66.1	23.7	67.1
32.0	23.6	48.1	23.4	51.3	23.0	53.9	22.7	56.2	22.5	58.2	22.3	60.0	22.1	61.6	21.8	63.0	21.6	64.2	21.5	65.4
34.0	21.7	44.5	21.4	48.1	21.2	51.1	20.8	53.6	20.5	55.8	20.3	57.8	20.2	59.5	19.9	61.0	19.6	62.4	19.5	63.6
36.0	19.9	40.7	19.7	44.8	19.5	48.1	19.3	50.9	18.9	53.3	18.6	55.5	18.4	57.3	18.2	59.0	18.0	60.5	17.8	61.8
38.0	18.4	36.6	18.2	41.2	18.0	45.0	17.8	48.1	17.7	50.8	17.1	53.1	17.0	55.1	16.7	56.9	16.4	58.5	16.3	60.0
40.0	17.1	32.0	16.9	37.4	16.8	41.7	16.4	45.2	16.3	48.1	16.0	50.6	15.6	52.9	15.4	54.8	15.1	56.6	14.9	58.1
42.0	40.8m× 16.6	30.0	15.7	33.2	15.5	38.1	15.3	42.1	15.1	45.3	14.8	48.1	14.7	50.5	14.1	52.7	13.9	54.5	13.8	56.2
44.0			43.4m× 14.9	30.0	14.4	34.3	14.2	38.8	14.0	42.4	13.7	45.5	13.6	48.1	13.3	50.4	12.8	52.5	12.7	54.3
46.0					13.5	30.0	13.2	35.2	13.0	39.3	12.7	42.7	12.6	45.6	12.3	48.1	12.0	50.3	11.9	52.3
48.0							12.4	31.3	12.1	36.0	11.8	39.8	11.7	43.0	11.4	45.7	11.1	48.1	11.0	50.2
50.0							48.6m× 12.1	30.0	11.3	32.3	11.0	36.7	10.8	40.2	10.6	43.2	10.3	45.8	10.1	48.1
52.0									51.2m× 10.8	30.0	10.3	33.3	10.1	37.3	9.9	40.6	9.5	43.5	9.3	45.9
54.0											53.8m× 9.6	30.0	9.4	34.1	9.1	37.8	8.8	41.0	8.6	43.7
56.0													8.7	30.7	8.4	34.9	8.1	38.3	7.9	41.3
58.0													56.4m× 8.6	30.0	7.8	31.7	7.4	35.6	7.3	38.8
60.0															59.0m× 7.5	30.0	6.8	32.6	6.6	36.2
62.0																	61.6m× 6.3	30.0	6.1	33.3
64.0																			5.5	30.3
66.0																			64.2m× 5.4	30.0
No. of Part line	7		7		6		6		5		5		5		4		4		4	

AUX. JIB RATED LIFTING LOADS

WITH STANDARD BOOM(92.0t Counterweight + 19.0t Carbody weight)

unit: ton

Boom length(m) Working radius(m)	18.0	21.0	24.0	27.0	30.0	33.0	36.0	39.0	42.0	45.0	48.0	51.0	54.0	57.0	60.0	63.0	66.0	69.0	72.0	
5.0																				
6.0	6.0m× 13.5	6.5m× 13.5																		
7.0	13.5	13.5	7.1m× 13.5	7.6m× 13.5																
8.0	13.5	13.5	13.5	13.5	8.1m× 13.5	8.6m× 13.5														
9.0	13.5	13.5	13.5	13.5	13.5	13.5	9.1m× 13.5	9.7m× 13.5												
10.0	13.5	13.5	13.5	13.5	13.5	13.5	13.5	13.5	10.2m× 13.5	10.7m× 13.5	11.2m× 13.5	11.7m× 13.5								
12.0	13.5	13.5	13.5	13.5	13.5	13.5	13.5	13.5	13.5	13.5	13.5	13.5	12.3m× 13.5	12.8m× 13.5	13.3m× 13.5	13.8m× 13.5				
14.0	13.5	13.5	13.5	13.5	13.5	13.5	13.5	13.5	13.5	13.5	13.5	13.5	13.5	13.5	13.5	13.5	14.3m× 13.5	14.9m× 13.5	15.4m× 13.5	
16.0	13.5	13.5	13.5	13.5	13.5	13.5	13.5	13.5	13.5	13.5	13.5	13.5	13.5	13.5	13.5	13.5	13.5	13.5	13.5	13.5
18.0	13.5	13.5	13.5	13.5	13.5	13.5	13.5	13.5	13.5	13.5	13.5	13.5	13.5	13.5	13.5	13.5	13.5	13.5	13.5	13.5
20.0	19.0m× 13.5	13.5	13.5	13.5	13.5	13.5	13.5	13.5	13.5	13.5	13.5	13.5	13.5	13.5	13.5	13.5	13.5	13.5	13.5	13.5
22.0		21.5m× 13.5	13.5	13.5	13.5	13.5	13.5	13.5	13.5	13.5	13.5	13.5	13.5	13.5	13.5	13.5	13.5	13.5	13.5	13.5
24.0			13.5	13.5	13.5	13.5	13.5	13.5	13.5	13.5	13.5	13.5	13.5	13.5	13.5	13.5	13.5	13.5	13.5	13.5
26.0			24.1m× 13.5	13.5	13.5	13.5	13.5	13.5	13.5	13.5	13.5	13.5	13.5	13.5	13.5	13.5	13.5	13.5	13.5	13.5
28.0				26.7m× 13.5	13.5	13.5	13.5	13.5	13.5	13.5	13.5	13.5	13.5	13.5	13.5	13.5	13.5	13.5	13.5	13.5
30.0					29.3m× 13.5	13.5	13.5	13.5	13.5	13.5	13.5	13.5	13.5	13.5	13.5	13.5	13.5	13.5	13.5	13.5
32.0						31.9m× 13.5	13.5	13.5	13.5	13.5	13.5	13.5	13.5	13.5	13.5	13.5	13.5	13.5	13.5	13.5
34.0							13.5	13.5	13.5	13.5	13.5	13.5	13.5	13.5	13.5	13.5	13.5	13.5	13.5	13.5
36.0							34.5m× 13.5	13.5	13.5	13.5	13.5	13.5	13.5	13.5	13.5	13.5	13.5	13.5	13.5	13.5
38.0								37.1m× 13.5	13.5	13.5	13.5	13.5	13.5	13.5	13.5	13.5	13.5	13.5	13.5	13.5
40.0									39.7m× 13.5	13.5	13.5	13.5	13.5	13.5	13.5	13.5	13.5	13.5	13.5	13.5
42.0										13.5	13.5	13.5	13.5	13.5	13.5	13.5	13.5	13.5	13.5	13.4
44.0										42.3m× 13.5	13.5	13.5	13.5	13.5	13.3	13.2	12.9	12.4	12.3	
46.0											44.9m× 13.5	13.1	12.8	12.6	12.3	12.2	11.9	11.6	11.5	
48.0												47.5m× 12.4	12.0	11.7	11.4	11.3	11.0	10.7	10.6	
50.0													11.0	10.9	10.6	10.4	10.2	9.9	9.7	
52.0													50.1m× 11.0	10.0	9.9	9.7	9.5	9.1	8.9	
54.0														52.7m× 9.8	9.1	9.0	8.7	8.3	8.2	
56.0															55.3m× 8.6	8.3	8.0	7.7	7.5	
58.0																57.9m× 7.7	7.4	7.0	6.9	
60.0																	6.8	6.4	6.2	
62.0																	60.5m× 6.7	5.8	5.6	
64.0																		63.1m× 5.5	5.1	
66.0																			65.7m× 4.6	
No. of Part line	1	1	1	1	1	1	1	1	1	1	1	1	1	1	1	1	1	1	1	1

Note:

- 1.THE VALUES OF RATED LOAD GIVEN IN THIS TABLE ARE THE LOAD OF WITHIN 78% OF TIPPING LOAD AND WITH THE FORWARD STABILITY OF 1.15 OR HIGHER FOR FULL SWINGING OF 360 DEGREES ON A FIRM LEVEL GROUND.
- 2.THE WORKING RADIUS REFERS TO THE HORIZONTAL DISTANCE FROM THE CENTER OF SWINGING TO THE HOOK AXIS.
- 3.THE ACTUAL LIFTING LOAD IS OBTAINED BY SUBTRACTING THE MASS OF ALL LIFTING EQUIPMENT SUCH AS THE MAIN HOOK,AUX. HOOK,ETC. FROM THE VALUES GIVEN IN THIS TABLE.

200t Hook...3.0t 90t Hook...1.6t 35t Hook...1.1t
 125t Hook...2.4t 60t Hook...1.4t 13.5t Hook...0.6t

LIGHT BOOM RATED LIFTING LOADS(92.0t Counterweight + 19.0t Carbody weight)

unit: ton

Boom length(m) Working radius(m)	72.0		75.0		78.0		81.0		84.0		87.0		90.0		93.0	
	Load	Angle	Load	Angle	Load	Angle	Load	Angle	Load	Angle	Load	Angle	Load	Angle	Load	Angle
14.0	14.4m× 37.5	80.0	14.9m× 35.0	80.0	15.4m× 33.0	80.0	16.0m× 31.5	80.0								
16.0	37.5	78.7	35.0	79.2	33.0	79.6	16.5m× 31.5	79.6	16.5m× 27.0	80.0	17.0m× 25.0	80.0	17.5m× 22.6	80.0	18.0m× 21.0	80.0
18.0	35.6	77.1	33.5	77.6	31.3	78.1	30.2	78.5	19.0m× 27.0	78.2	19.5m× 25.0	78.3	19.0m× 22.6	79.0	18.2m× 21.0	79.9
20.0	33.7	75.4	32.1	76.0	29.8	76.6	28.8	77.1	26.7	77.6	24.7	77.9	22.1	78.3	20.0	78.7
22.0	32.0	73.8	30.7	74.4	28.5	75.1	27.4	75.6	26.0	76.1	23.7	76.6	21.0	77.0	18.9	77.5
24.0	30.5	72.1	29.3	72.9	27.2	73.5	26.2	74.2	25.0	74.7	22.5	75.2	19.9	75.7	17.8	76.2
26.0	28.9	70.4	27.8	71.2	26.1	72.0	25.1	72.7	23.9	73.3	21.4	73.8	18.9	74.4	16.9	74.9
28.0	26.6	68.7	25.9	69.6	24.9	70.4	24.0	71.2	22.9	71.9	20.3	72.5	18.0	73.1	16.0	73.6
30.0	24.0	67.0	23.8	68.0	23.6	68.9	23.0	69.7	21.9	70.4	19.2	71.1	17.1	71.7	15.3	72.3
32.0	22.0	65.3	21.9	66.3	21.9	67.3	21.7	68.2	20.5	69.0	18.2	69.6	16.3	70.4	14.5	71.0
34.0	20.4	63.5	20.2	64.6	20.0	65.7	19.8	66.6	19.2	67.5	17.3	68.2	15.4	69.0	13.8	69.7
36.0	18.9	61.7	18.6	62.9	18.5	64.1	18.3	65.1	18.0	66.0	16.4	66.8	14.6	67.6	13.1	68.4
38.0	17.4	59.9	17.2	61.2	17.1	62.4	17.0	63.5	16.9	64.5	15.4	65.3	13.8	66.2	12.5	67.0
40.0	16.0	58.0	15.9	59.4	15.8	60.7	15.7	61.9	15.7	63.0	14.5	63.9	13.0	64.8	11.8	65.7
42.0	14.8	56.1	14.7	57.6	14.6	59.0	14.5	60.3	14.4	61.5	13.6	62.4	12.3	63.4	11.2	64.3
44.0	13.7	54.2	13.6	55.8	13.5	57.3	13.4	58.6	13.3	59.9	12.7	60.9	11.6	61.9	10.7	62.9
46.0	12.7	52.2	12.6	53.9	12.5	55.5	12.4	57.0	12.3	58.3	11.9	59.4	11.0	60.5	10.2	61.5
48.0	11.9	50.1	11.8	52.0	11.7	53.7	11.6	55.3	11.5	56.7	11.2	57.8	10.4	59.0	9.8	60.1
50.0	11.1	48.0	11.0	50.0	10.9	51.9	10.8	53.5	10.7	55.0	10.5	56.2	9.8	57.5	9.4	58.7
52.0	10.4	45.8	10.3	48.0	10.2	50.0	10.1	51.7	10.0	53.3	9.8	54.6	9.3	56.0	8.9	57.2
54.0	9.7	43.5	9.6	45.9	9.5	48.0	9.4	49.9	9.3	51.6	9.2	53.0	8.7	54.4	8.5	55.7
56.0	9.0	41.2	8.9	43.7	8.8	46.0	8.7	48.0	8.6	49.8	8.5	51.3	8.1	52.8	7.8	54.2
58.0	8.3	38.7	8.2	41.5	8.1	43.9	8.0	46.1	7.9	48.0	7.8	49.6	7.5	51.2	7.2	52.7
60.0	7.7	36.0	7.6	39.1	7.5	41.7	7.4	44.1	7.3	46.2	7.2	47.8	6.9	49.5	6.7	51.1
62.0	7.2	33.2	7.1	36.6	7.0	39.5	6.9	42.0	6.8	44.2	6.7	46.0	6.3	47.8	6.1	49.5
64.0	6.7	30.2	6.6	33.9	6.5	37.1	6.4	39.8	6.3	42.2	6.2	44.1	5.8	46.0	5.6	47.8
66.0	64.1m× 6.7	30.0	6.2	31.1	6.1	34.6	6.0	37.6	5.9	40.1	5.8	42.1	5.3	44.2	5.1	46.1
68.0			66.7m× 6.1	30.0	5.7	31.9	5.6	35.2	5.5	38.0	5.4	40.1	4.9	42.4	4.6	44.4
70.0					69.3m× 5.4	30.0	5.2	32.6	5.1	35.7	5.0	38.0	4.5	40.4	4.1	42.6
72.0							71.9m× 4.8	30.0	4.7	33.3	4.6	35.8	4.0	38.4	3.6	40.7
74.0									4.3	30.7	4.2	33.5	3.5	36.3	3.1	38.7
76.0									74.5m× 4.1	30.0	3.7	31.0	3.1	34.1	2.6	36.7
78.0											76.7m× 3.5	30.0	2.7	31.7	2.2	34.6
80.0													79.3m× 2.4	30.0	1.8	32.3
No. of Part line	3		3		3		3		3		2		2		2	

Note:

- THE VALUES OF RATED LOAD GIVEN IN THIS TABLE ARE THE LOAD OF WITHIN 78% OF TIPPING LOAD AND WITH THE FORWARD STABILITY OF 1.15 OR HIGHER FOR FULL SWINGING OF 360 DEGREES ON A FIRM LEVEL GROUND.
- THE FIGURE ENCLOSED WITHIN BOLD LINES IN THIS TABLE ARE THE VALUES DETERMINED BASED ON THE STRENGTH OF THE BOOM, ETC.
- THE WORKING RADIUS REFERS TO THE HORIZONTAL DISTANCE FROM THE CENTER OF SWINGING TO THE HOOK AXIS.
- FOR THE OPERATION, BE SURE TO RAISE THE A-FRAME.
- THE LENGTH OF THE BOOM WHICH CAN BE MOUNTED WITH THE AUX. JIB IS 72.0m~90.0m.
- THE ACTUAL LIFTING LOAD IS OBTAINED BY SUBTRACTING THE MASS OF ALL LIFTING EQUIPMENT SUCH AS THE MAIN HOOK, AUX. HOOK, ETC. FROM THE VALUES GIVEN IN THIS TABLE.
60t Hook...1.4t 35t Hook...1.1t 13.5t Hook...0.6t
- WHEN THE AUX. JIB IS MOUNTED, RATED LOAD WITH THE MAIN HOOK IS OBTAINED BY SUBTRACTING 0.8ton (INCLUDING THE MASS OF THE AUX. HOOK) FROM THE VALUES GIVEN IN THIS TABLE.
- THE RATED LOAD OF THE AUX. JIB IS OBTAINED BY SUBTRACTING 0.4t FROM THE VALUES GIVEN IN THIS TABLE CORRESPONDING TO THE LENGTH OF THE MOUNTED BOOM.
BUT THE MAX. RATED LOAD IS 13.5ton.
- WHEN THE MAIN HOOK IS MOUNTED THE LOAD WHICH CAN BE LIFTED WITH THE JIB IS GIVEN BY SUBTRACTING THE TOTAL MASS OF MAIN AND AUX. HOOKS FROM THE VALUE IN THIS TABLE.
- THE RATED LOAD ARE LIMITED ACCORDING TO THE WIRE ROPE PART LINE AS SHOWN BELOW:
1 PART OF LINE ... UP TO 13.5 ton 2 PART OF LINE ... UP TO 25.0ton 3 PART OF LINE ... UP TO 37.5ton

AUX. JIB RATED LIFTING LOADS

WITH LIGHT BOOM(92.0t Counterweight + 19.0t Carbody weight)

unit : ton

Working radius(m) Boom length(m)	72.0	75.0	78.0	81.0	84.0	87.0	90.0
14.0	15.2m× 13.5	15.7m× 13.5					
16.0	13.5	13.5	16.3m× 13.5	16.8m× 13.5	17.3m× 13.5	17.8m× 13.5	
18.0	13.5	13.5	13.5	13.5	13.5	13.5	18.3m× 13.5
20.0	13.5	13.5	13.5	13.5	13.5	13.5	13.5
22.0	13.5	13.5	13.5	13.5	13.5	13.5	13.5
24.0	13.5	13.5	13.5	13.5	13.5	13.5	13.5
26.0	13.5	13.5	13.5	13.5	13.5	13.5	13.5
28.0	13.5	13.5	13.5	13.5	13.5	13.5	13.5
30.0	13.5	13.5	13.5	13.5	13.5	13.5	13.5
32.0	13.5	13.5	13.5	13.5	13.5	13.5	13.5
34.0	13.5	13.5	13.5	13.5	13.5	13.5	13.5
36.0	13.5	13.5	13.5	13.5	13.5	13.5	13.5
38.0	13.5	13.5	13.5	13.5	13.5	13.5	13.4
40.0	13.5	13.5	13.5	13.5	13.5	13.5	12.6
42.0	13.5	13.5	13.5	13.5	13.5	13.2	11.9
44.0	13.3	13.2	13.1	13.0	12.9	12.3	11.2
46.0	12.3	12.2	12.1	12.0	11.9	11.5	10.6
48.0	11.5	11.4	11.3	11.2	11.1	10.8	10.0
50.0	10.7	10.6	10.5	10.4	10.3	10.1	9.4
52.0	10.0	9.9	9.8	9.7	9.6	9.4	8.9
54.0	9.3	9.2	9.1	9.0	8.9	8.8	8.3
56.0	8.6	8.5	8.4	8.3	8.2	8.1	7.7
58.0	7.9	7.8	7.7	7.6	7.5	7.4	7.1
60.0	7.3	7.2	7.1	7.0	6.9	6.8	6.5
62.0	6.8	6.7	6.6	6.5	6.4	6.3	5.9
64.0	6.3	6.2	6.1	6.0	5.9	5.8	5.4
66.0	65.6m× 6.0	5.8	5.7	5.6	5.5	5.4	4.9
68.0		5.7	5.3	5.2	5.1	5.0	4.5
70.0		68.2m× 5.4	5.0	4.8	4.7	4.6	4.1
72.0			70.8m× 4.7	4.4	4.3	4.2	3.6
74.0				73.4m× 4.1	3.9	3.8	3.1
76.0					3.4	3.3	2.7
78.0						3.1	2.3
80.0						78.6m× 2.8	80.0m× 2.0
No. of Part line	1	1	1	1	1	1	1

Note:

- 1.THE VALUES OF RATED LOAD GIVEN IN THIS TABLE ARE THE LOAD OF WITHIN 78% OF TIPPING LOAD AND WITH THE FORWARD STABILITY OF 1.15 OR HIGHER FOR FULL SWINGING OF 360 DEGREES ON A FIRM LEVEL GROUND.
- 2.THE WORKING RADIUS REFERS TO THE HORIZONTAL DISTANCE FROM THE CENTER OF SWINGING TO THE HOOK AXIS.
- 3.THE ACTUAL LIFTING LOAD IS OBTAINED BY SUBTRACTING THE MASS OF ALL LIFTING EQUIPMENT SUCH AS THE MAIN HOOK,AUX. HOOK,ETC. FROM THE VALUES GIVEN IN THIS TABLE.

60t Hook...1.4t 35t Hook...1.1t 13.5t Hook...0.6t

CRANE JIB RATED LIFTING LOADS

WITH STANDARD BOOM(92.0t Counterweight + 19.0t Carbody weight)

unit: ton

Boom length(m)	45.0									
Jib length(m)	13.0		19.0		25.0		31.0		37.0	
Jib offset angle	10°	30°	10°	30°	10°	30°	10°	30°	10°	30°
Working radius (m)										
14.0	25.0									
16.0	25.0		16.5m× 22.0							
18.0	25.0	19.6	20.4		18.5m× 13.5					
20.0	25.0	18.9	19.7		13.0		20.5m× 7.2			
22.0	24.3	18.4	19.0	22.5m× 13.5	12.7		7.1		22.5m× 5.0	
24.0	23.3	17.6	18.3	13.5	12.5		7.0		5.0	
26.0	22.3	16.9	17.7	13.4	12.0	8.7	6.8		4.7	
28.0	21.4	16.3	17.2	12.9	11.8	8.5	6.7		4.5	
30.0	20.4	15.8	16.7	12.6	11.5	8.4	6.6	5.2	4.4	
32.0	19.5	15.3	16.2	12.2	11.2	8.2	6.5	5.1	4.0	
34.0	18.8	14.8	15.8	11.7	10.7	8.0	6.3	5.0	3.9	2.9
36.0	18.0	14.4	15.0	11.4	10.5	7.9	6.2	4.8	3.7	2.8
38.0	17.3	14.1	14.2	10.9	10.3	7.7	6.0	4.7	3.6	2.7
40.0	16.4	13.7	13.6	10.7	10.1	7.5	5.8	4.6	3.4	2.6
42.0	15.2	13.5	13.0	10.3	9.7	7.4	5.7	4.5	3.3	2.5
44.0	14.1	13.2	12.5	10.1	9.6	7.2	5.4	4.4	3.2	2.5
46.0	13.1	13.0	12.0	9.8	9.4	7.1	5.3	4.3	3.1	2.4
48.0	12.2	12.4	11.6	9.7	9.3	6.9	5.1	4.2	3.0	2.3
50.0	11.3	11.5	11.2	9.4	9.0	6.7	5.0	4.1	2.9	2.2
52.0	10.6	10.7	10.8	9.3	8.8	6.6	4.9	4.0	2.8	2.2
54.0	53.0m× 10.0	53.5m× 10.0	10.4	9.1	8.7	6.4	4.8	4.0	2.7	2.1
56.0			9.7	9.0	8.6	6.3	4.6	3.9	2.6	2.1
58.0			9.1	8.9	8.4	6.3	4.5	3.8	2.6	2.0
60.0			58.5m× 8.8	8.7	8.2	6.3	4.4	3.8	2.5	2.0
62.0					8.0	6.3	4.4	3.8	2.3	1.9
64.0					7.7	6.3	4.3	3.7	2.3	1.9
66.0					64.5m× 7.7	6.3	4.2	3.7	2.2	1.9
68.0							4.1	3.7	2.2	1.8
70.0							4.1	3.7	2.1	1.8
72.0								3.7	2.1	1.8
74.0									2.0	1.8
76.0									75.0m× 2.0	1.8
78.0										1.8
80.0										
82.0										
84.0										
86.0										
88.0										
90.0										
No. of Part line	2	2	2	1	1	1	1	1	1	1

Note:

- 1.THE VALUES OF RATED LOAD GIVEN IN THIS TABLE ARE THE LOAD OF WITHIN 78% OF TIPPING LOAD AND WITH THE FORWARD STABILITY OF 1.15 OR HIGHER FOR FULL SWINGING OF 360 DEGREES ON A FIRM LEVEL GROUND.
- 2.THE WORKING RADIUS REFERS TO THE HORIZONTAL DISTANCE FROM THE CENTER OF SWINGING TO THE HOOK AXIS.
- 3.THE ACTUAL LIFTING LOAD IS OBTAINED BY SUBTRACTING THE MASS OF ALL LIFTING EQUIPMENT SUCH AS THE MAIN HOOK,AUX. HOOK,ETC. FROM THE VALUES GIVEN IN THIS TABLE.

200t Hook...3.0t 90t Hook...1.6t 35t Hook...1.1t
 125t Hook...2.4t 60t Hook...1.4t 13.5t Hook...0.6t

CRANE JIB RATED LIFTING LOADS

WITH STANDARD BOOM(92.0t Counterweight + 19.0t Carbody weight)

unit: to:

Boom length(m)	48.0									
Jib length(m)	13.0		19.0		25.0		31.0		37.0	
Jib offset angle	10°	30°	10°	30°	10°	30°	10°	30°	10°	30°
Working radius (m)										
14.0										
16.0	15.0m× 25.0		17.0m× 21.9							
18.0	25.0	18.5m× 19.6	20.7		19.0m× 13.1					
20.0	25.0	19.0	19.9		13.0		21.0m× 7.2			
22.0	24.7	18.6	19.2	23.0m× 13.5	12.8		7.1		23.0m× 5.0	
24.0	23.8	17.9	18.6	13.5	12.6		7.0		5.0	
26.0	22.9	17.2	18.0	13.5	12.4	26.5m× 8.8	6.9		4.7	
28.0	22.0	16.6	17.5	13.2	12.0	8.6	6.8		4.5	
30.0	21.1	16.1	17.0	12.9	11.5	8.4	6.6	30.5m× 5.2	4.4	
32.0	20.1	15.6	16.5	12.2	11.2	8.3	6.5	5.1	4.2	
34.0	19.3	15.1	16.0	11.9	11.0	8.1	6.4	5.0	4.0	34.5m× 2.9
36.0	18.7	14.7	15.5	11.7	10.7	8.0	6.3	4.8	3.9	2.8
38.0	17.5	14.3	14.8	11.1	10.5	7.8	6.2	4.8	3.7	2.8
40.0	16.1	14.0	14.1	10.9	10.3	7.7	5.8	4.7	3.6	2.7
42.0	14.9	13.7	13.5	10.5	9.9	7.5	5.7	4.5	3.4	2.6
44.0	13.8	13.4	13.0	10.3	9.7	7.3	5.5	4.4	3.3	2.5
46.0	12.8	13.1	12.5	10.1	9.6	7.2	5.4	4.3	3.2	2.4
48.0	11.9	12.2	12.0	9.8	9.4	7.0	5.3	4.3	3.1	2.3
50.0	11.1	11.3	11.5	9.7	9.3	6.9	5.1	4.2	3.0	2.3
52.0	10.3	10.5	10.8	9.4	9.0	6.7	5.0	4.1	2.9	2.2
54.0	9.6	9.7	10.1	9.3	8.8	6.6	4.9	4.0	2.8	2.2
56.0	55.5m× 9.0	9.0	9.4	9.1	8.7	6.4	4.8	4.0	2.7	2.1
58.0		56.5m× 8.8	8.8	9.1	8.6	6.3	4.6	3.9	2.6	2.1
60.0			8.2	8.5	8.4	6.3	4.5	3.8	2.6	2.0
62.0			61.0m× 7.8	7.9	8.1	6.3	4.4	3.8	2.5	2.0
64.0				62.5m× 7.6	7.6	6.3	4.4	3.8	2.3	1.9
66.0					7.1	6.3	4.3	3.7	2.3	1.9
68.0					67.0m× 6.9	6.3	4.2	3.7	2.2	1.9
70.0						68.5m× 6.3	4.1	3.7	2.2	1.8
72.0							4.1	3.7	2.1	1.8
74.0							72.5m× 4.1	3.7	2.1	1.8
76.0								74.5m× 3.7	2.0	1.8
78.0									77.5m× 2.0	1.8
80.0										1.8
82.0										80.5m× 1.8
84.0										
86.0										
88.0										
90.0										
No. of Part line	2	2	2	1	1	1	1	1	1	1

Note:

- 1.THE VALUES OF RATED LOAD GIVEN IN THIS TABLE ARE THE LOAD OF WITHIN 78% OF TIPPING LOAD AND WITH THE FORWARD STABILITY OF 1.15 OR HIGHER FOR FULL SWINGING OF 360 DEGREES ON A FIRM LEVEL GROUND.
- 2.THE WORKING RADIUS REFERS TO THE HORIZONTAL DISTANCE FROM THE CENTER OF SWINGING TO THE HOOK AXIS.
- 3.THE ACTUAL LIFTING LOAD IS OBTAINED BY SUBTRACTING THE MASS OF ALL LIFTING EQUIPMENT SUCH AS THE MAIN HOOK,AUX. HOOK,ETC. FROM THE VALUES GIVEN IN THIS TABLE.

200t Hook...3.0t 90t Hook...1.6t 35t Hook...1.1t
 125t Hook...2.4t 60t Hook...1.4t 13.5t Hook...0.6t

CRANE JIB RATED LIFTING LOADS

WITH STANDARD BOOM(92.0t Counterweight + 19.0t Carbody weight)

unit : to:

Boom length(m)	51.0									
Jib length(m)	13.0		19.0		25.0		31.0		37.0	
Jib offset angle Working radius (m)	10°	30°	10°	30°	10°	30°	10°	30°	10°	30°
14.0	15.5m× 25.0									
16.0	25.0		17.5m× 21.8							
18.0	25.0	19.0m× 19.6	20.9		19.5m× 13.2					
20.0	25.0	19.1	20.1		13.1		21.5m× 7.2			
22.0	25.0	18.7	19.5	23.5m× 13.5	12.9		7.1		23.5m× 5.0	
24.0	24.2	18.2	18.8	13.5	12.7		7.0		5.0	
26.0	23.3	17.5	18.3	13.5	12.4	27.0m× 8.8	6.9		4.7	
28.0	22.5	16.9	17.7	13.3	12.0	8.6	6.8		4.5	
30.0	21.6	16.4	17.2	12.9	11.8	8.5	6.7	31.0m× 5.2	4.4	
32.0	20.8	15.9	16.8	12.6	11.5	8.3	6.6	5.2	4.2	
34.0	19.9	15.4	16.3	12.2	11.2	8.2	6.5	5.1	4.0	35.0m× 2.9
36.0	18.8	15.0	15.9	11.7	11.0	8.0	6.3	4.8	3.9	2.8
38.0	17.3	14.6	15.3	11.4	10.5	7.9	6.2	4.8	3.7	2.8
40.0	15.9	14.3	14.6	11.1	10.3	7.7	6.0	4.7	3.6	2.7
42.0	14.7	13.9	14.0	10.7	10.1	7.6	5.8	4.6	3.4	2.6
44.0	13.6	13.7	13.4	10.5	9.9	7.4	5.7	4.5	3.3	2.5
46.0	12.6	13.0	12.9	10.3	9.7	7.3	5.5	4.4	3.2	2.5
48.0	11.7	12.0	12.2	10.0	9.6	7.2	5.4	4.3	3.1	2.4
50.0	10.8	11.1	11.3	9.8	9.4	7.0	5.3	4.2	3.0	2.3
52.0	10.0	10.3	10.6	9.7	9.1	6.9	5.1	4.1	3.0	2.3
54.0	9.3	9.6	9.8	9.4	9.0	6.7	5.0	4.1	2.9	2.2
56.0	8.7	8.9	9.2	9.3	8.8	6.6	4.9	4.0	2.8	2.1
58.0	8.1	8.2	8.6	8.9	8.7	6.4	4.7	4.0	2.7	2.1
60.0		59.0m× 7.8	8.0	8.3	8.3	6.3	4.6	3.9	2.6	2.0
62.0			7.5	7.7	7.8	6.3	4.5	3.8	2.6	2.0
64.0			7.0	7.2	7.3	6.2	4.4	3.8	2.4	2.0
66.0				65.0m× 6.8	6.9	6.2	4.4	3.8	2.3	1.9
68.0					6.5	6.2	4.3	3.7	2.3	1.9
70.0					69.5m× 6.0	6.2	4.2	3.7	2.2	1.9
72.0						71.0m× 6.1	4.2	3.7	2.2	1.8
74.0							4.1	3.7	2.1	1.8
76.0							75.0m× 4.1	3.7	2.1	1.8
78.0								77.0m× 3.7	2.0	1.8
80.0									2.0	1.8
82.0										1.8
84.0										83.0m× 1.8
86.0										
88.0										
90.0										
No. of Part line	2	2	2	1	1	1	1	1	1	1

Note:

- 1.THE VALUES OF RATED LOAD GIVEN IN THIS TABLE ARE THE LOAD OF WITHIN 78% OF TIPPING LOAD AND WITH THE FORWARD STABILITY OF 1.15 OR HIGHER FOR FULL SWINGING OF 360 DEGREES ON A FIRM LEVEL GROUND.
- 2.THE WORKING RADIUS REFERS TO THE HORIZONTAL DISTANCE FROM THE CENTER OF SWINGING TO THE HOOK AXIS.
- 3.THE ACTUAL LIFTING LOAD IS OBTAINED BY SUBTRACTING THE MASS OF ALL LIFTING EQUIPMENT SUCH AS THE MAIN HOOK,AUX. HOOK,ETC. FROM THE VALUES GIVEN IN THIS TABLE.

200t Hook...3.0t 90t Hook...1.6t 35t Hook...1.1t
 125t Hook...2.4t 60t Hook...1.4t 13.5t Hook...0.6t

CRANE JIB RATED LIFTING LOADS

WITH STANDARD BOOM(92.0t Counterweight + 19.0t Carbody weight)

unit : to:

Boom length(m)	54.0									
Jib length(m)	13.0		19.0		25.0		31.0		37.0	
Jib offset angle	10°	30°	10°	30°	10°	30°	10°	30°	10°	30°
Working radius (m)										
14.0										
16.0	25.0									
18.0	25.0	19.5m× 19.6	21.8							
20.0	25.0	19.2	20.4		13.1					
22.0	25.0	18.8	19.7		12.9		7.2			
24.0	24.6	18.4	19.1	13.5	12.7		7.1		24.5m× 5.0	
26.0	23.8	17.8	18.5	13.5	12.5	27.5m× 8.8	7.0		5.0	
28.0	23.0	17.2	18.0	13.4	12.4	8.7	6.8		4.7	
30.0	22.2	16.6	17.5	13.1	11.8	8.5	6.7	31.5m× 5.2	4.5	
32.0	21.3	16.1	17.0	12.8	11.5	8.4	6.6	5.2	4.4	
34.0	20.3	15.7	16.6	12.2	11.2	8.2	6.5	5.1	4.2	35.5m× 2.9
36.0	18.6	15.3	16.2	11.9	11.0	8.1	6.4	5.0	4.0	2.9
38.0	17.1	14.9	15.8	11.7	10.7	8.0	6.3	4.8	3.9	2.8
40.0	15.7	14.5	15.1	11.4	10.5	7.8	6.2	4.8	3.7	2.7
42.0	14.5	14.2	14.4	10.9	10.3	7.7	6.0	4.7	3.6	2.6
44.0	13.4	13.8	13.8	10.7	10.1	7.5	5.8	4.5	3.4	2.5
46.0	12.3	12.8	12.9	10.5	9.9	7.4	5.7	4.4	3.3	2.5
48.0	11.4	11.8	12.0	10.1	9.7	7.3	5.5	4.3	3.2	2.4
50.0	10.6	10.9	11.1	10.0	9.6	7.1	5.4	4.3	3.1	2.3
52.0	9.8	10.1	10.3	9.8	9.3	7.0	5.3	4.2	3.0	2.3
54.0	9.1	9.4	9.6	9.5	9.1	6.8	5.1	4.1	2.9	2.2
56.0	8.5	8.7	9.0	9.4	9.0	6.7	5.0	4.1	2.8	2.2
58.0	7.9	8.0	8.4	8.8	8.7	6.6	4.8	4.0	2.7	2.1
60.0	7.2	7.4	7.8	8.1	8.1	6.4	4.7	3.9	2.6	2.1
62.0	61.0m× 6.9	6.8	7.2	7.6	7.6	6.3	4.6	3.9	2.6	2.0
64.0			6.7	7.0	7.1	6.3	4.5	3.8	2.5	2.0
66.0			6.1	6.4	6.7	6.2	4.4	3.8	2.4	2.0
68.0			66.5m× 6.0	5.8	6.2	6.2	4.4	3.8	2.3	1.9
70.0					5.7	6.1	4.3	3.7	2.3	1.9
72.0					5.2	5.5	4.2	3.7	2.3	1.9
74.0					72.5m× 5.1	5.0	4.2	3.7	2.2	1.8
76.0							4.1	3.7	2.2	1.8
78.0							77.5m× 4.1	3.7	2.1	1.8
80.0								3.7	2.0	1.8
82.0									2.0	1.8
84.0									83.0m× 2.0	1.8
86.0										1.8
88.0										
90.0										
No. of Part line	2	2	2	1	1	1	1	1	1	1

Note:

- 1.THE VALUES OF RATED LOAD GIVEN IN THIS TABLE ARE THE LOAD OF WITHIN 78% OF TIPPING LOAD AND WITH THE FORWARD STABILITY OF 1.15 OR HIGHER FOR FULL SWINGING OF 360 DEGREES ON A FIRM LEVEL GROUND.
- 2.THE WORKING RADIUS REFERS TO THE HORIZONTAL DISTANCE FROM THE CENTER OF SWINGING TO THE HOOK AXIS.
- 3.THE ACTUAL LIFTING LOAD IS OBTAINED BY SUBTRACTING THE MASS OF ALL LIFTING EQUIPMENT SUCH AS THE MAIN HOOK,AUX. HOOK,ETC. FROM THE VALUES GIVEN IN THIS TABLE.

200t Hook...3.0t 90t Hook...1.6t 35t Hook...1.1t
 125t Hook...2.4t 60t Hook...1.4t 13.5t Hook...0.6t

CRANE JIB RATED LIFTING LOADS

WITH STANDARD BOOM(92.0t Counterweight + 19.0t Carbody weight)

unit: to

Boom length(m)	57.0									
Jib length(m)	13.0		19.0		25.0		31.0		37.0	
Jib offset angle	10°	30°	10°	30°	10°	30°	10°	30°	10°	30°
Working radius (m)	10°	30°	10°	30°	10°	30°	10°	30°	10°	30°
14.0										
16.0	16.5m× 25.0									
18.0	25.0		18.5m× 22.0							
20.0	25.0	19.6	20.6		20.5m× 13.2					
22.0	25.0	18.9	19.9		13.0		22.5m× 7.2			
24.0	25.0	18.6	19.3	24.5m× 13.5	12.8		7.1		25.0m× 5.0	
26.0	24.2	18.0	18.7	13.5	12.6		7.0		5.0	
28.0	23.4	17.4	18.2	13.5	12.4	8.7	6.9		4.7	
30.0	22.6	16.9	17.7	13.2	12.0	8.6	6.8		4.5	
32.0	21.3	16.4	17.3	12.9	11.8	8.4	6.7	5.2	4.4	
34.0	20.1	15.9	16.8	12.6	11.5	8.3	6.6	5.1	4.2	
36.0	18.3	15.5	16.4	12.2	11.2	8.2	6.5	5.0	4.0	2.9
38.0	16.8	15.1	16.0	11.7	11.0	8.0	6.3	4.8	3.9	2.8
40.0	15.4	14.7	15.6	11.4	10.7	7.9	6.2	4.8	3.7	2.8
42.0	14.2	14.4	14.8	11.1	10.5	7.8	6.0	4.7	3.7	2.7
44.0	13.1	13.6	13.6	10.9	10.3	7.6	5.8	4.6	3.6	2.6
46.0	12.1	12.5	12.6	10.7	10.1	7.5	5.7	4.5	3.4	2.5
48.0	11.2	11.6	11.7	10.3	9.9	7.4	5.5	4.4	3.3	2.5
50.0	10.3	10.7	10.8	10.1	9.6	7.2	5.4	4.3	3.2	2.4
52.0	9.6	9.9	10.1	10.0	9.4	7.1	5.3	4.3	3.1	2.3
54.0	8.8	9.1	9.4	9.8	9.3	7.0	5.1	4.2	3.0	2.3
56.0	8.2	8.4	8.7	9.2	9.0	6.8	5.0	4.1	2.9	2.2
58.0	7.5	7.8	8.1	8.5	8.4	6.7	4.9	4.0	2.8	2.2
60.0	6.9	7.1	7.5	7.9	7.9	6.6	4.8	4.0	2.7	2.1
62.0	6.2	6.4	6.9	7.3	7.4	6.4	4.7	3.9	2.6	2.1
64.0	63.5m× 5.8	5.8	6.3	6.7	6.9	6.3	4.6	3.9	2.6	2.0
66.0			5.8	6.1	6.3	6.3	4.5	3.8	2.5	2.0
68.0			5.2	5.5	5.8	6.2	4.4	3.8	2.4	2.0
70.0			69.0m× 5.0	5.0	5.3	5.7	4.4	3.8	2.4	1.9
72.0				70.5m× 4.8	4.9	5.2	4.3	3.7	2.3	1.9
74.0					4.4	4.7	4.2	3.7	2.3	1.9
76.0					75.0m× 4.2	4.2	4.2	3.7	2.2	1.8
78.0						76.5m× 4.1	4.0	3.7	2.2	1.8
80.0							3.7	3.7	2.1	1.8
82.0							80.5m× 3.5	3.5	2.1	1.8
84.0								82.5m× 3.4	2.0	1.8
86.0									85.5m× 2.0	1.8
88.0										1.8
90.0										88.5m× 1.8
No. of Part line	2	2	2	1	1	1	1	1	1	1

Note:

- 1.THE VALUES OF RATED LOAD GIVEN IN THIS TABLE ARE THE LOAD OF WITHIN 78% OF TIPPING LOAD AND WITH THE FORWARD STABILITY OF 1.15 OR HIGHER FOR FULL SWINGING OF 360 DEGREES ON A FIRM LEVEL GROUND.
- 2.THE WORKING RADIUS REFERS TO THE HORIZONTAL DISTANCE FROM THE CENTER OF SWINGING TO THE HOOK AXIS.
- 3.THE ACTUAL LIFTING LOAD IS OBTAINED BY SUBTRACTING THE MASS OF ALL LIFTING EQUIPMENT SUCH AS THE MAIN HOOK,AUX. HOOK,ETC. FROM THE VALUES GIVEN IN THIS TABLE.

200t Hook...3.0t 90t Hook...1.6t 35t Hook...1.1t
125t Hook...2.4t 60t Hook...1.4t 13.5t Hook...0.6t

CRANE JIB RATED LIFTING LOADS
WITH STANDARD BOOM(92.0t Counterweight + 19.0t Carbody weight) unit: to:

Boom length(m)	60.0									
Jib length(m)	13.0		19.0		25.0		31.0		37.0	
Jib offset angle	10°	30°	10°	30°	10°	30°	10°	30°	10°	30°
Working radius (m)	10°	30°	10°	30°	10°	30°	10°	30°	10°	30°
14.0										
16.0	17.0m× 25.0									
18.0	25.0		19.5m× 21.8							
20.0	25.0	21.0m× 19.6	20.8		21.0m× 13.2					
22.0	25.0	19.0	20.1		13.0		23.0m× 7.2			
24.0	24.6	18.7	19.5	25.0m× 13.5	12.9		7.1		25.5m× 5.0	
26.0	23.6	18.3	19.0	13.5	12.7		7.0		5.0	
28.0	22.7	17.7	18.4	13.5	12.4	28.5m× 8.8	6.9		4.7	
30.0	22.1	17.1	17.9	13.3	12.0	8.6	6.8		4.5	
32.0	21.5	16.6	17.5	12.9	11.8	8.5	6.7	32.5m× 5.2	4.4	
34.0	19.8	16.2	17.0	12.6	11.5	8.4	6.6	5.2	4.4	
36.0	18.1	15.7	16.6	12.2	11.2	8.2	6.5	5.1	4.2	36.5m× 2.9
38.0	16.6	15.3	16.3	11.9	11.0	8.1	6.4	5.0	4.0	2.8
40.0	15.2	15.0	15.8	11.7	10.7	8.0	6.3	4.8	3.9	2.8
42.0	13.9	14.5	14.5	11.4	10.5	7.8	6.2	4.8	3.7	2.7
44.0	12.8	13.4	13.4	11.1	10.3	7.7	6.0	4.7	3.6	2.6
46.0	11.8	12.3	12.4	10.7	10.1	7.6	5.8	4.6	3.4	2.5
48.0	10.9	11.4	11.5	10.5	9.9	7.5	5.7	4.4	3.3	2.5
50.0	10.1	10.5	10.6	10.3	9.7	7.3	5.5	4.3	3.2	2.4
52.0	9.3	9.7	9.8	10.1	9.6	7.2	5.4	4.3	3.2	2.3
54.0	8.6	8.9	9.1	9.7	9.4	7.1	5.3	4.2	3.1	2.3
56.0	7.9	8.2	8.5	9.0	8.8	6.9	5.1	4.1	3.0	2.3
58.0	7.2	7.5	7.8	8.3	8.2	6.8	5.0	4.1	2.9	2.2
60.0	6.5	6.8	7.2	7.7	7.7	6.7	4.9	4.0	2.8	2.2
62.0	5.9	6.2	6.6	7.1	7.2	6.6	4.8	4.0	2.7	2.1
64.0	5.4	5.5	6.0	6.4	6.6	6.4	4.7	3.9	2.6	2.1
66.0	4.8	5.0	5.4	5.8	6.0	6.3	4.6	3.9	2.6	2.0
68.0		67.0m× 4.7	4.9	5.3	5.5	6.0	4.5	3.8	2.5	2.0
70.0			4.4	4.7	5.0	5.5	4.4	3.8	2.4	2.0
72.0			71.5m× 4.0	4.2	4.6	5.0	4.4	3.8	2.4	1.9
74.0				73.0m× 3.9	4.1	4.5	4.3	3.8	2.3	1.9
76.0					3.7	4.0	4.0	3.7	2.3	1.9
78.0					77.5m× 3.4	3.6	3.6	3.7	2.2	1.8
80.0						79.0m× 3.3	3.3	3.6	2.2	1.8
82.0							3.1	3.2	2.1	1.8
84.0							83.0m× 2.8	2.9	2.1	1.8
86.0								85.0m× 2.7		1.8
88.0										1.8
90.0										
No. of Part line	2	2	2	1	1	1	1	1	1	1

Note:

- 1.THE VALUES OF RATED LOAD GIVEN IN THIS TABLE ARE THE LOAD OF WITHIN 78% OF TIPPING LOAD AND WITH THE FORWARD STABILITY OF 1.15 OR HIGHER FOR FULL SWINGING OF 360 DEGREES ON A FIRM LEVEL GROUND.
- 2.THE WORKING RADIUS REFERS TO THE HORIZONTAL DISTANCE FROM THE CENTER OF SWINGING TO THE HOOK AXIS.
- 3.THE ACTUAL LIFTING LOAD IS OBTAINED BY SUBTRACTING THE MASS OF ALL LIFTING EQUIPMENT SUCH AS THE MAIN HOOK,AUX. HOOK,ETC. FROM THE VALUES GIVEN IN THIS TABLE.

200t Hook...3.0t 90t Hook...1.6t 35t Hook...1.1t
125t Hook...2.4t 60t Hook...1.4t 13.5t Hook...0.6t

CRANE JIB RATED LIFTING LOADS
WITH STANDARD BOOM(92.0t Counterweight + 19.0t Carbody weight) unit: to:

Boom length(m)	63.0									
Jib length(m)	13.0		19.0		25.0		31.0		37.0	
Jib offset angle	10°	30°	10°	30°	10°	30°	10°	30°	10°	30°
Working radius (m)	10°	30°	10°	30°	10°	30°	10°	30°	10°	30°
14.0										
16.0	17.5m× 25.0									
18.0	25.0									
20.0	25.0	21.5m× 19.6	20.9		21.5m× 13.2					
22.0	24.9	19.1	20.3		13.1					
24.0	24.3	18.8	19.7	25.5m× 13.5	12.9		7.2			
26.0	23.7	18.5	19.2	13.5	12.7		7.1		5.0	
28.0	23.2	17.9	18.6	13.5	12.6	29.0m× 8.8	7.0		4.7	
30.0	22.6	17.4	18.2	13.4	12.4	8.6	6.9		4.7	
32.0	21.8	16.9	17.7	13.2	12.0	8.5	6.8	33.0m× 5.2	4.5	
34.0	19.7	16.4	17.3	12.9	11.8	8.4	6.7	5.2	4.4	
36.0	18.0	16.0	16.9	12.6	11.5	8.3	6.6	5.1	4.2	37.0m× 2.9
38.0	16.5	15.6	16.5	12.2	11.2	8.2	6.5	5.0	4.0	2.8
40.0	15.1	15.2	15.6	11.9	11.0	8.0	6.3	4.8	3.9	2.8
42.0	13.8	14.5	14.4	11.4	10.7	7.9	6.2	4.8	3.7	2.8
44.0	12.7	13.3	13.3	11.1	10.5	7.8	6.0	4.7	3.7	2.7
46.0	11.7	12.3	12.3	10.9	10.3	7.7	6.0	4.6	3.6	2.6
48.0	10.8	11.3	11.3	10.7	10.1	7.5	5.8	4.5	3.4	2.5
50.0	10.0	10.4	10.5	10.5	9.9	7.4	5.7	4.4	3.3	2.5
52.0	9.2	9.6	9.7	10.3	9.7	7.3	5.5	4.3	3.2	2.4
54.0	8.5	8.9	9.0	9.6	9.2	7.2	5.4	4.3	3.1	2.3
56.0	7.7	8.1	8.3	8.9	8.6	7.0	5.3	4.2	3.0	2.3
58.0	7.0	7.4	7.7	8.3	8.0	6.9	5.1	4.1	3.0	2.2
60.0	6.4	6.7	7.0	7.6	7.6	6.8	5.0	4.1	2.9	2.2
62.0	5.8	6.0	6.4	6.9	7.0	6.7	4.9	4.0	2.8	2.1
64.0	5.2	5.4	5.8	6.3	6.4	6.5	4.8	4.0	2.7	2.1
66.0	4.7	4.9	5.3	5.7	5.8	6.3	4.7	3.9	2.6	2.0
68.0	4.2	4.3	4.8	5.2	5.3	5.9	4.6	3.9	2.6	2.0
70.0	68.5m× 4.0	69.5m× 3.9	4.3	4.6	4.8	5.3	4.5	3.8	2.5	2.0
72.0			3.8	4.1	4.4	4.8	4.4	3.8	2.4	1.9
74.0			3.4	3.6	4.0	4.4	4.1	3.8	2.4	1.9
76.0				75.5m× 3.3	3.5	3.9	3.7	3.8	2.3	1.9
78.0					3.2	3.5	3.4	3.7	2.3	1.9
80.0					2.8	3.0	3.2	3.4	2.2	1.8
82.0							2.9	3.0	2.2	1.8
84.0							2.5	2.8		1.8
86.0								2.5		1.8
88.0										
90.0										
No. of Part line	2	2	2	1	1	1	1	1	1	1

Note:

- 1.THE VALUES OF RATED LOAD GIVEN IN THIS TABLE ARE THE LOAD OF WITHIN 78% OF TIPPING LOAD AND WITH THE FORWARD STABILITY OF 1.15 OR HIGHER FOR FULL SWINGING OF 360 DEGREES ON A FIRM LEVEL GROUND.
- 2.THE WORKING RADIUS REFERS TO THE HORIZONTAL DISTANCE FROM THE CENTER OF SWINGING TO THE HOOK AXIS.
- 3.THE ACTUAL LIFTING LOAD IS OBTAINED BY SUBTRACTING THE MASS OF ALL LIFTING EQUIPMENT SUCH AS THE MAIN HOOK,AUX. HOOK,ETC. FROM THE VALUES GIVEN IN THIS TABLE.

200t Hook...3.0t 90t Hook...1.6t 35t Hook...1.1t
125t Hook...2.4t 60t Hook...1.4t 13.5t Hook...0.6t

CRANE JIB RATED LIFTING LOADS

WITH STANDARD BOOM(92.0t Counterweight + 19.0t Carbody weight)

unit: to:

Boom length(m)	66.0									
Jib length(m)	13.0		19.0		25.0		31.0		37.0	
Jib offset angle	10°	30°	10°	30°	10°	30°	10°	30°	10°	30°
Working radius (m)										
14.0										
16.0										
18.0	25.0									
20.0	25.0		20.5m× 21.8							
22.0	25.0	19.5	20.5		13.1					
24.0	24.5	18.9	19.9		13.0		24.5m× 7.2			
26.0	24.0	18.6	19.4	13.5	12.8		7.1		26.5m× 5.0	
28.0	23.3	18.1	18.8	13.5	12.6		7.0		5.0	
30.0	22.6	17.6	18.4	13.5	12.4	8.7	6.9		4.7	
32.0	21.5	17.1	17.9	13.2	12.0	8.6	6.8	33.5m× 5.2	4.5	
34.0	19.5	16.6	17.5	12.9	11.8	8.4	6.7	5.2	4.4	
36.0	17.7	16.2	17.1	12.6	11.5	8.3	6.6	5.1	4.2	37.5m× 2.9
38.0	16.2	15.8	16.7	12.2	11.2	8.2	6.5	5.0	4.2	2.9
40.0	14.8	15.4	15.4	11.9	11.0	8.1	6.4	4.8	4.0	2.8
42.0	13.6	14.2	14.1	11.7	11.0	8.0	6.3	4.8	3.9	2.8
44.0	12.5	13.1	13.0	11.4	10.7	7.8	6.2	4.7	3.7	2.7
46.0	11.5	12.0	12.0	11.1	10.5	7.7	6.0	4.6	3.6	2.6
48.0	10.6	11.1	11.1	10.9	10.3	7.6	5.8	4.6	3.4	2.5
50.0	9.7	10.2	10.2	10.7	10.1	7.5	5.7	4.5	3.4	2.5
52.0	8.9	9.4	9.5	10.2	9.7	7.4	5.5	4.4	3.3	2.4
54.0	8.1	8.6	8.7	9.4	9.0	7.3	5.5	4.3	3.2	2.4
56.0	7.4	7.8	8.0	8.7	8.4	7.1	5.4	4.3	3.1	2.3
58.0	6.7	7.1	7.3	8.0	8.0	7.0	5.3	4.2	3.0	2.3
60.0	6.0	6.4	6.6	7.3	7.2	6.9	5.1	4.1	2.9	2.2
62.0	5.4	5.7	6.0	6.6	6.6	6.8	5.0	4.1	2.8	2.2
64.0	4.8	5.1	5.4	6.0	6.0	6.5	4.9	4.0	2.8	2.1
66.0	4.3	4.5	4.9	5.4	5.5	6.1	4.8	4.0	2.7	2.1
68.0	3.8	4.0	4.4	4.8	5.0	5.6	4.7	3.9	2.6	2.0
70.0	3.3	3.5	3.9	4.3	4.5	5.0	4.6	3.9	2.6	2.0
72.0		3.0	3.5	3.8	4.0	4.5	4.3	3.8	2.5	2.0
74.0			3.0	3.3	3.6	4.1	3.9	3.8	2.4	1.9
76.0			2.6	2.9	3.2	3.6	3.5	3.8	2.4	1.9
78.0				2.5	2.8	3.2	3.2	3.5	2.3	1.9
80.0					2.4	2.7	2.9	3.1	2.3	1.9
82.0					2.1	2.3	2.5	2.9		1.8
84.0							2.2	2.6		1.8
86.0								2.2		
88.0										
90.0										
No. of Part line	2	2	2	1	1	1	1	1	1	1

Note:

- 1.THE VALUES OF RATED LOAD GIVEN IN THIS TABLE ARE THE LOAD OF WITHIN 78% OF TIPPING LOAD AND WITH THE FORWARD STABILITY OF 1.15 OR HIGHER FOR FULL SWINGING OF 360 DEGREES ON A FIRM LEVEL GROUND.
- 2.THE WORKING RADIUS REFERS TO THE HORIZONTAL DISTANCE FROM THE CENTER OF SWINGING TO THE HOOK AXIS.
- 3.THE ACTUAL LIFTING LOAD IS OBTAINED BY SUBTRACTING THE MASS OF ALL LIFTING EQUIPMENT SUCH AS THE MAIN HOOK,AUX. HOOK,ETC. FROM THE VALUES GIVEN IN THIS TABLE.

200t Hook...3.0t 90t Hook...1.6t 35t Hook...1.1t
 125t Hook...2.4t 60t Hook...1.4t 13.5t Hook...0.6t

CRANE JIB RATED LIFTING LOADS

WITH STANDARD BOOM(92.0t Counterweight + 19.0t Carbody weight)

unit : to:

Boom length(m)	69.0									
Jib length(m)	13.0		19.0		25.0		31.0		37.0	
Jib offset angle	10°	30°	10°	30°	10°	30°	10°	30°	10°	30°
Working radius (m)										
14.0										
16.0										
18.0	18.5m× 25.0									
20.0	25.0		21.0m× 21.8							
22.0	25.0	22.5m× 19.5	20.7		23.0m× 13.1					
24.0	24.7	19.0	20.1		13.0		25.0m× 7.2			
26.0	24.2	18.7	19.5	26.5m× 13.5	12.8		7.1		27.0m× 5.0	
28.0	23.6	18.3	19.0	13.5	12.7		7.0		5.0	
30.0	23.2	17.8	18.6	13.5	12.4	30.5m× 8.8	6.9		4.7	
32.0	21.1	17.3	18.1	13.3	12.4	8.6	6.8		4.5	
34.0	19.3	16.8	17.7	13.1	12.0	8.5	6.7	5.2	4.4	
36.0	17.6	16.4	17.3	12.9	11.8	8.4	6.7	5.1	4.4	
38.0	16.1	16.0	16.6	12.6	11.5	8.3	6.6	5.1	4.2	2.9
40.0	14.7	15.4	15.3	12.2	11.2	8.1	6.5	5.0	4.0	2.8
42.0	13.4	14.1	14.0	11.9	11.0	8.0	6.3	4.8	3.9	2.8
44.0	12.3	13.0	12.9	11.6	10.7	7.9	6.2	4.8	3.7	2.7
46.0	11.3	11.9	11.8	11.4	10.5	7.8	6.2	4.7	3.7	2.7
48.0	10.4	10.9	10.9	11.1	10.3	7.7	6.0	4.6	3.6	2.6
50.0	9.5	10.0	10.1	10.8	10.1	7.6	5.8	4.5	3.4	2.5
52.0	8.7	9.2	9.3	10.1	9.4	7.5	5.7	4.4	3.3	2.5
54.0	7.9	8.4	8.5	9.3	8.7	7.3	5.5	4.3	3.2	2.4
56.0	7.1	7.6	7.8	8.6	8.3	7.2	5.4	4.3	3.2	2.3
58.0	6.4	6.8	7.0	7.8	7.7	7.1	5.3	4.2	3.1	2.3
60.0	5.7	6.1	6.4	7.1	7.0	7.0	5.3	4.1	3.0	2.2
62.0	5.1	5.5	5.8	6.4	6.4	6.8	5.1	4.1	2.9	2.2
64.0	4.6	4.9	5.2	5.8	5.8	6.5	5.0	4.1	2.8	2.2
66.0	4.0	4.3	4.6	5.2	5.2	5.9	4.9	4.0	2.8	2.1
68.0	3.5	3.8	4.1	4.6	4.7	5.4	4.8	4.0	2.7	2.1
70.0	3.0	3.2	3.6	4.1	4.2	4.8	4.3	3.9	2.6	2.0
72.0	2.6	2.8	3.2	3.6	3.8	4.3	3.9	3.9	2.6	2.0
74.0		2.3	2.8	3.1	3.3	3.8	3.7	3.8	2.5	2.0
76.0			2.3	2.7	2.9	3.4	3.4	3.6	2.4	1.9
78.0				2.2	2.5	2.9	3.0	3.2	2.4	1.9
80.0					2.2	2.5	2.6	2.9		1.9
82.0						2.1	2.2	2.8		1.9
84.0								2.4		
86.0										
88.0										
90.0										
No. of Part line	2	2	2	1	1	1	1	1	1	1

Note:

- 1.THE VALUES OF RATED LOAD GIVEN IN THIS TABLE ARE THE LOAD OF WITHIN 78% OF TIPPING LOAD AND WITH THE FORWARD STABILITY OF 1.15 OR HIGHER FOR FULL SWINGING OF 360 DEGREES ON A FIRM LEVEL GROUND.
- 2.THE WORKING RADIUS REFERS TO THE HORIZONTAL DISTANCE FROM THE CENTER OF SWINGING TO THE HOOK AXIS.
- 3.THE ACTUAL LIFTING LOAD IS OBTAINED BY SUBTRACTING THE MASS OF ALL LIFTING EQUIPMENT SUCH AS THE MAIN HOOK,AUX. HOOK,ETC. FROM THE VALUES GIVEN IN THIS TABLE.

200t Hook...3.0t 90t Hook...1.6t 35t Hook...1.1t
 125t Hook...2.4t 60t Hook...1.4t 13.5t Hook...0.6t

CRANE JIB RATED LIFTING LOADS

WITH STANDARD BOOM(92.0t Counterweight + 19.0t Carbody weight)

unit: to:

Boom length(m)	72.0									
Jib length(m)	13.0		19.0		25.0		31.0		37.0	
Jib offset angle	10°	30°	10°	30°	10°	30°	10°	30°	10°	30°
Working radius (m)	10°	30°	10°	30°	10°	30°	10°	30°	10°	30°
14.0										
16.0										
18.0	19.0m× 25.0									
20.0	25.0		21.5m× 21.8							
22.0	25.0	23.0m× 19.5	20.8		23.5m× 13.2					
24.0	24.9	19.0	20.2		13.1		25.5m× 7.2			
26.0	24.4	18.8	19.7	27.0m× 13.5	12.7		7.1		27.5m× 5.0	
28.0	23.9	18.5	19.2	13.5	12.3		7.0		5.0	
30.0	22.8	18.0	18.7	13.5	11.9	31.0m× 8.8	7.0		4.7	
32.0	20.7	17.5	18.3	13.4	11.5	8.6	6.9		4.7	
34.0	19.1	17.0	17.9	13.2	11.1	8.5	6.8	34.5m× 5.2	4.5	
36.0	17.4	16.6	17.5	12.9	10.7	8.4	6.7	5.2	4.4	
38.0	15.9	16.2	16.4	12.6	10.3	8.3	6.6	5.1	4.2	38.5m× 2.9
40.0	14.5	15.2	15.1	12.2	10.0	8.2	6.5	5.0	4.0	2.8
42.0	13.2	14.0	13.9	11.9	9.8	8.1	6.4	4.8	4.0	2.8
44.0	12.1	12.8	12.7	11.7	9.6	8.0	6.3	4.8	3.9	2.8
46.0	11.1	11.8	11.7	11.4	9.4	7.9	6.2	4.7	3.7	2.7
48.0	10.2	10.8	10.7	11.1	9.2	7.8	6.0	4.6	3.6	2.6
50.0	9.3	9.9	9.9	10.7	9.0	7.6	5.8	4.6	3.6	2.5
52.0	8.4	9.0	9.1	9.9	8.8	7.5	5.8	4.5	3.4	2.5
54.0	7.6	8.2	8.3	9.1	8.6	7.4	5.7	4.4	3.3	2.4
56.0	6.8	7.3	7.5	8.3	8.1	7.3	5.5	4.3	3.2	2.4
58.0	6.1	6.6	6.8	7.6	7.4	7.2	5.4	4.3	3.1	2.3
60.0	5.5	5.9	6.1	6.8	6.7	7.1	5.3	4.2	3.1	2.3
62.0	4.9	5.2	5.5	6.2	6.1	6.6	5.1	4.1	3.0	2.2
64.0	4.3	4.6	4.9	5.5	5.5	6.4	5.1	4.1	2.9	2.2
66.0	3.7	4.1	4.4	4.9	5.0	5.7	5.0	4.0	2.8	2.1
68.0	3.2	3.5	3.8	4.4	4.4	5.1	4.5	4.0	2.7	2.1
70.0	2.8	3.0	3.4	3.9	3.9	4.6	4.1	3.9	2.7	2.1
72.0	2.3	2.5	2.9	3.4	3.5	4.1	3.8	3.9	2.6	2.0
74.0		2.1	2.5	2.9	3.1	3.6	3.6	3.8	2.6	2.0
76.0			2.1	2.4	2.6	3.2	3.1	3.4	2.5	2.0
78.0					2.3	2.7	2.7	3.0		1.9
80.0						2.3	2.3	2.9		1.9
82.0								2.5		
84.0								2.1		
86.0										
88.0										
90.0										
No. of Part line	2	2	2	1	1	1	1	1	1	1

Note:

- 1.THE VALUES OF RATED LOAD GIVEN IN THIS TABLE ARE THE LOAD OF WITHIN 78% OF TIPPING LOAD AND WITH THE FORWARD STABILITY OF 1.15 OR HIGHER FOR FULL SWINGING OF 360 DEGREES ON A FIRM LEVEL GROUND.
- 2.THE WORKING RADIUS REFERS TO THE HORIZONTAL DISTANCE FROM THE CENTER OF SWINGING TO THE HOOK AXIS.
- 3.THE ACTUAL LIFTING LOAD IS OBTAINED BY SUBTRACTING THE MASS OF ALL LIFTING EQUIPMENT SUCH AS THE MAIN HOOK,AUX. HOOK,ETC. FROM THE VALUES GIVEN IN THIS TABLE.

200t Hook...3.0t 90t Hook...1.6t 35t Hook...1.1t
 125t Hook...2.4t 60t Hook...1.4t 13.5t Hook...0.6t

6. 3rd HOISTING WINCH (Special specifications)

Specification to use the third drum in substitution for the main drum

(1) Specification

Maximum lifting capacity × working radius: 60 ton × 16.0 m

Maximum boom length: 30 m

Rope length: 220 m

maximum height of hook above ground: 27.5 m

Rope speed hoisting/lowering: 100 m/min

Note: The value marked with “ ” will be changed according to the loads given.

Rope part lines

60t hook: 6 part lines

Boom hoist: 20 part lines

Standard counterweight: 92.0 ton

Carbody weight: 19.0 ton

Crane total weight: Approx. 210 ton (with 18 m boom)

Average ground bearing pressure: 113 kPa (1.15 kgf/cm²)

(2) Wire Rope

Purpose	Rope dia (mm)	Breaking Strength(kN)	Rope Type
Load hoisting	φ 28	585	IWRC 6×Fi(29)
Boom hoisting	φ 22.4	356	IWRC 6×WS(31)
Boom suspension	φ 40	1360	IWRC 6×P·WS(36)

(3) 3rd HOISTING WINCH RATED LIFTING LOADS

(92.0t Counterweight + 19.0t Carbody weight)

unit : ton

Boom length(m) Working radius(m)	18.0		21.0		24.0		27.0		30.0	
	Load	Angle	Load	Angle	Load	Angle	Load	Angle	Load	Angle
5.0	5.2m × 60.0	80.0	5.7m × 60.0	80.0						
6.0	60.0	77.3	60.0	79.2	6.2m × 60.0	80.0	6.7m × 60.0	80.0		
7.0	60.0	74.0	60.0	76.4	60.0	78.1	60.0	79.4	7.3m × 60.0	80.0
8.0	60.0	70.6	60.0	73.5	60.0	75.6	60.0	77.3	60.0	78.6
9.0	60.0	67.2	60.0	70.6	60.0	73.1	60.0	75.1	60.0	76.6
10.0	60.0	63.7	60.0	67.7	60.0	70.6	60.0	72.9	60.0	74.6
12.0	60.0	56.2	60.0	61.6	60.0	65.4	60.0	68.3	60.0	70.6
14.0	60.0	47.9	60.0	55.1	60.0	60.0	60.0	63.6	60.0	66.5
16.0	60.0	38.4	60.0	48.0	60.0	54.2	60.0	58.8	60.0	62.2
18.0	17.4m × 55.2	30.0	54.1	39.9	53.8	48.0	53.4	53.6	52.6	57.7
20.0			47.2	30.0	46.9	41.1	46.7	48.0	45.7	53.1
22.0					41.4	32.9	41.2	41.9	40.4	48.0
24.0					22.6m × 39.8	30.0	36.2	34.9	36.0	42.6
26.0							25.2m × 33.9	30.0	32.4	36.5
28.0									27.8m × 29.6	30.0
No. of Part line	6		6		6		6		6	

Note:

1. THE VALUES OF RATED LOAD GIVEN IN THIS TABLE ARE THE LOAD OF WITHIN 78% OF TIPPING LOAD AND WITH THE FORWARD STABILITY OF 1.15 OR HIGHER FOR FULL SWINGING OF 360 DEGREES ON A FIRM LEVEL GROUND.
2. THE WORKING RADIUS REFERS TO THE HORIZONTAL DISTANCE FROM THE CENTER OF SWINGING TO THE HOOK AXIS.
3. FOR THE OPERATION, BE SURE TO RAISE THE A-FRAME.
4. THE ACTUAL LIFTING LOAD IS OBTAINED BY SUBTRACTING THE MASS OF ALL LIFTING EQUIPMENT SUCH AS THE MAIN HOOK, AUX. HOOK, ETC. FROM THE VALUES GIVEN IN THIS TABLE.
60tHook...1.4t 35tHook...1.1t 13.5tHook...0.6t
5. THE RATED LOAD ARE LIMITED ACCORDING TO THE WIRE ROPE PART LINE AS SHOWN BELOW:

(1 PART OF LINE ... NOT AVAILABLE)	4 PART OF LINE ... UP TO 44.0ton
2 PART OF LINE ... UP TO 22.0ton	5 PART OF LINE ... UP TO 55.0ton
3 PART OF LINE ... UP TO 33.0ton	6 PART OF LINE ... UP TO 60.0ton

(4) 3rd Hoisting Winch Working Ranges Diagram

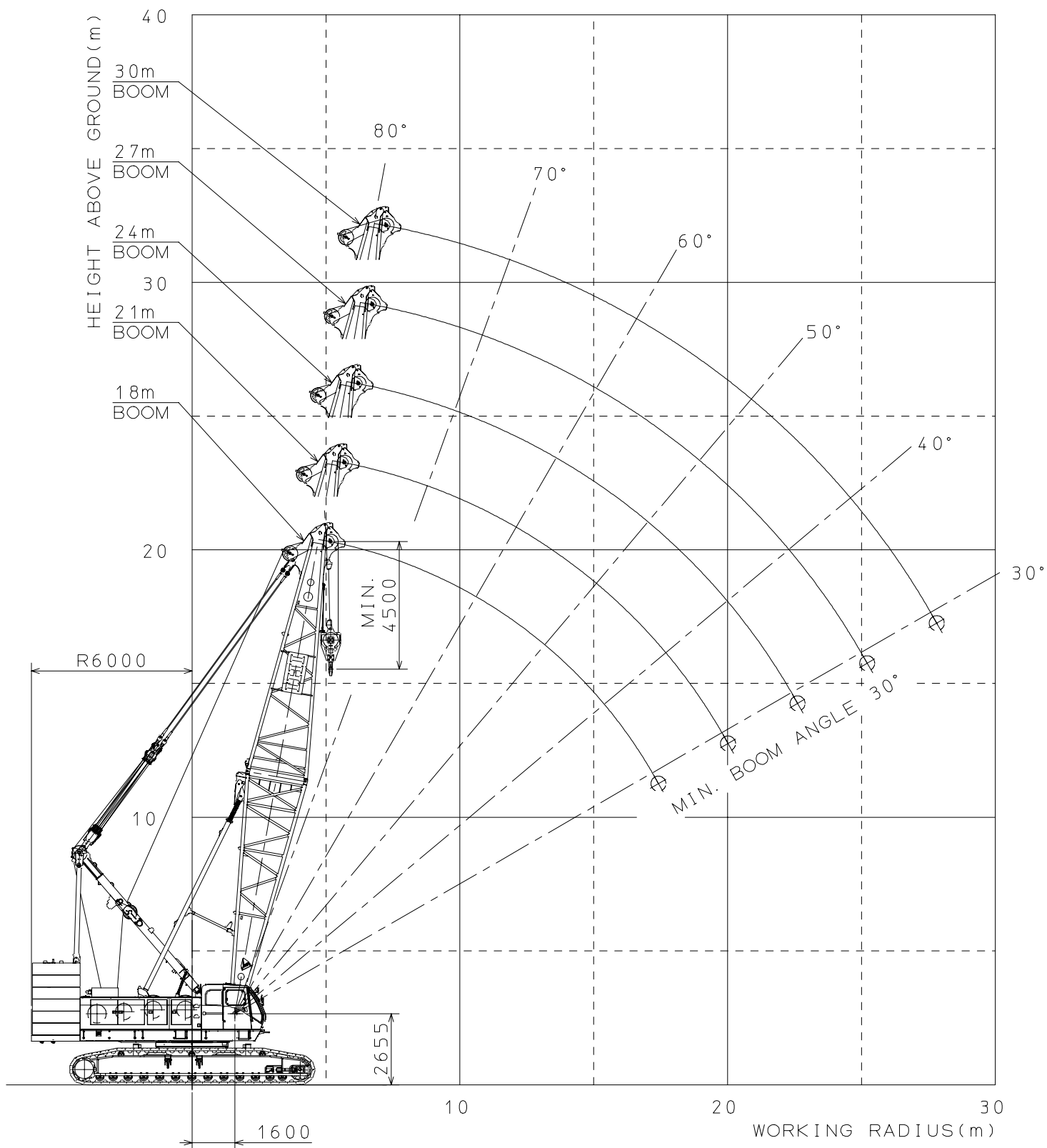

7. CLAMSHELL SPECIFICATION (Special specifications)

(1) Specification

Maximum lift above ground	46.0m (18m Boom + 2.5m ³ Bucket)
Rope speed	
Bucket closing:	※ 120m/min
Bucket holding:	※ 120m/min
Boom hoisting/lowering:	※ 34m/min×2
Note: The value marked with “ ” will be changed according to the loads given.	
Rope part lines	
Bucket closing:	6 part lines (all bucket common)
Bucket holding:	1 part line (all bucket common)
Boom hoisting:	20 part lines
Maximum lifting capacity:	12.5 ton (Bucket weight + Load)
Standard counterweight:	92.0 ton
Carbody weight:	19.0 ton
Crane total weight:	Approx. 211 ton (18m Boom + 2.5m ³ Bucket)
Average ground bearing pressure:	113 kPa (1.15 kgf/cm ²)

(2) Clamshell Bucket Specification

Classifications	Capacity (m ³)	Weight (ton)	Classifications
Heavy digging (Dredging)	2.0	6.5	Option
General digging · Heavy duty	2.5	5.5	Standard
Medium duty	3.0	5.0	Option
Light duty	4.0	4.5	Option
Light duty	5.0	4.0	Option

(3) Wire Rope

Purpose	Rope dia (mm)	Breaking Strength (kN)	Rope Type
Bucket closing	φ 28	585	IWRC 6×Fi(29)
Bucket suspension	φ 28	585	IWRC 6×Fi(29)
Boom hoist	φ 22	356	IWRC 6×WS(31)
Boom suspension	φ 34	1020	IWRC 6×P·WS(36)
Hydraulic tugline	φ 10	54	6×19

(4) Working Radius And Rated Loads

Boom length (m)	18				21				24				27			
Boom angle (°)	35	45	55	65	35	45	55	65	35	45	55	65	35	45	55	65
Working radius (m)	16.9	14.9	12.6	9.9	19.3	17.1	14.3	11.2	21.8	19.2	16.0	12.4	24.3	21.3	17.7	13.7
Rated lifting loads (ton)	12.5	12.5	12.5	12.5	12.5	12.5	12.5	12.5	12.5	12.5	12.5	12.5	12.5	12.5	12.5	12.5
Boom point height(m)	12.6	15.1	17.1	18.8	14.3	17.2	19.6	21.5	16.0	19.3	22.1	24.2	17.8	21.4	24.5	26.9
Max. dumping height (m)	6.6	9.1	11.1	12.8	8.3	11.2	13.6	15.5	10.0	13.3	16.1	18.2	11.8	15.4	18.5	20.9
Max. digging depth (m)	39.4	36.9	34.9	33.2	37.7	34.8	32.4	30.5	36.0	32.7	29.9	27.8	34.2	30.6	27.5	25.1

Note:

1. The maximum boom length is 27 meters.
2. The rated lifting load indicates the maximum lifting weight of a bucket and its content. Select an appropriate bucket depending on content, so as not to exceed the rated lifting load.
3. The working radius refers to the horizontal distance from the center of swinging to the vertical line through the center of the bucket.
4. Maximum dumping height depends on the height of a bucket attached. In the chart, top clearance of 6 meters is assumed.
5. Maximum digging depth is the value calculated by subtracting maximum dumping height from the maximum lifting range of 46 meters.
6. The aux. jib cannot be used for bucket work.
7. When lowering a bucket using half brake, ensure that the drop height is about 10 meters or less. Use powered lowering as well as free fall when the drop height is higher than 10 meters.
8. The maximum weight of a bucket is 6.5 tons, but it is necessary to use a lighter bucket depending on work cycle and drop height.
9. Avoid sudden acceleration or deceleration while slewing the machine, which would apply dragging the load sideway to the boom. Be careful especially when a longer boom is used.

(5) Clamshell General Dimensions

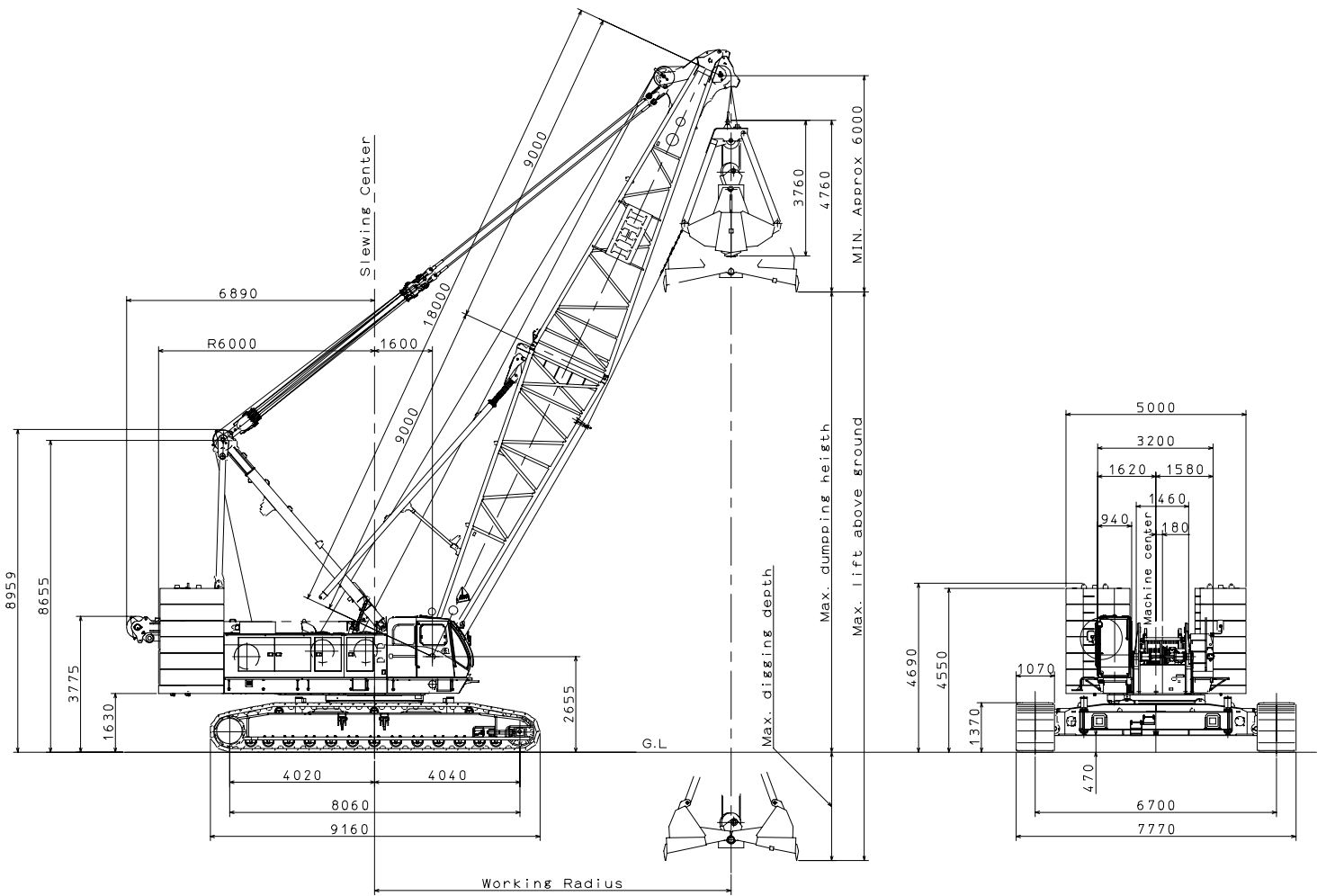

(6) Clamshell Working Ranges Diagram

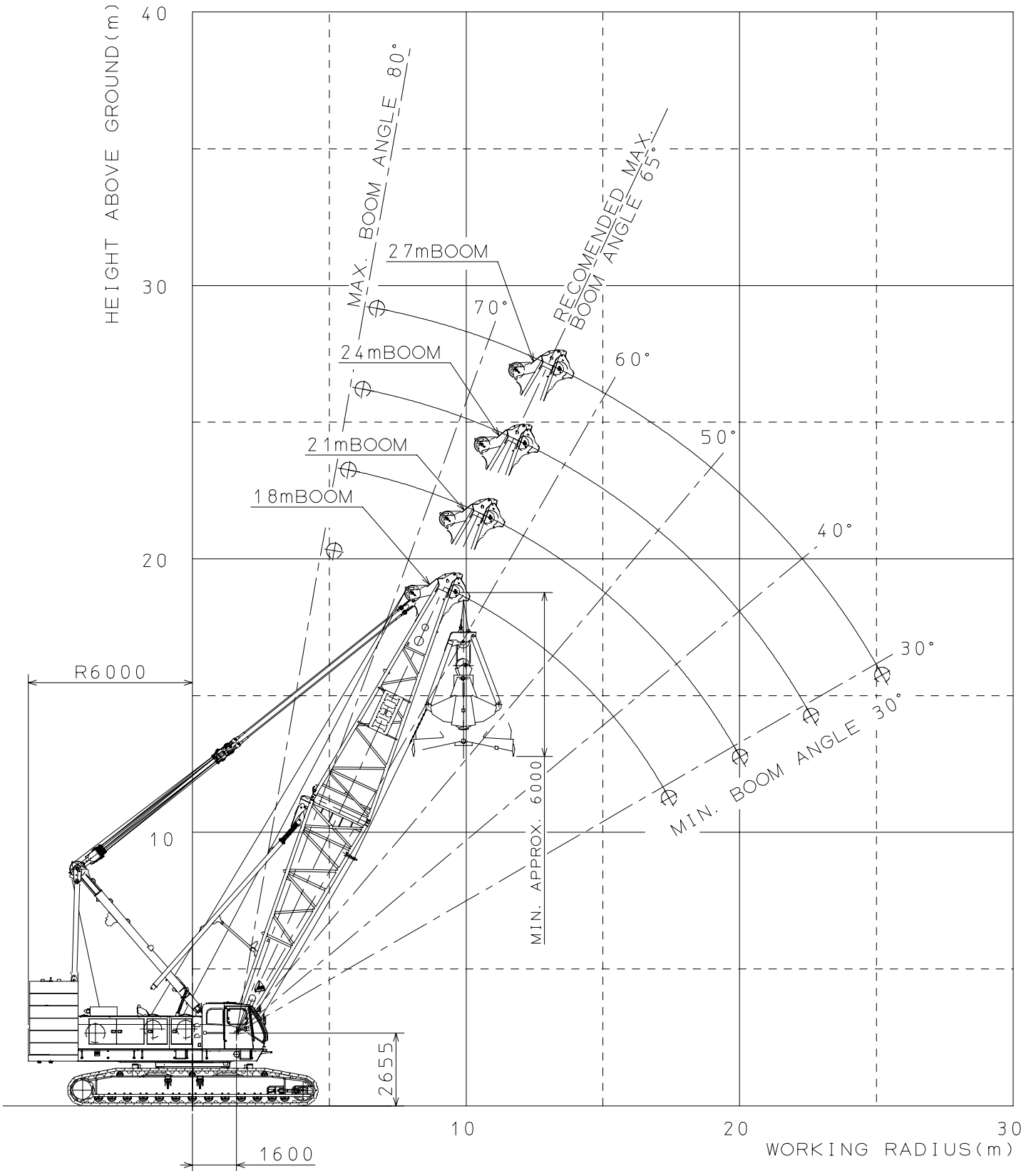

8. STANDARD EQUIPMENT

(1) Safety Devices

- Moment Limiter :Over-load prevention device.
Alarm at 90%, automatic stop at 100%
- Hook over-winding :Alarm and automatic stopper
- Boom over-hoisting :Automatic stopper
- 2nd boom throw-out :All winch function(non resetable)
- Boom over-turning :Double-stem telescopic
- Swing lock :Pin-lock
- Main and Auxiliary drum lock :Pawl
- Boom hoisting drum lock :Pawl
- Lever lock :Remote control circuit line cut off
- Automatic brake system
- Slewing warning buzzer(with voice alarm)
- Travel warning buzzer(with voice alarm)
- Engine start voice alarm
- Switch of emergency stop the engine
- Hydraulic circuit valves

(2) Instrument

- Tachometer(displayed by Moment Limiter)
- Hour meter
- Hydraulic pressure gauge for control circuit
- Fuel level gauge
- Engine coolant temperature gauge(indicated in OK monitor)
- Engine diagnostic monitor

(3) Auxiliary DEVICE

- Ultra low speed control
- Speed control for slewing and winch
- Pump power shift device
- Remote controller for jack and crawler connect cylinder

(4) Lighting

- Work light :24V x 80W
- Room light :24V x 10W

(5) Others

- Air conditioner
- Front windshield wiper
- Ceiling wiper
- Sun shade
- Sun visor
- Storage pouch
- Tool box
- large-sized cabinet
- Reclining operator's seat
- Floor mat
- Step for operator's cab(break fold type)
- Radio
- Cigarette lighter
- Ashtray
- Rear view mirrors(on both sides)
- Warning horn
- Electric fuel pump
- "A" frame hoist cylinders
- Bronze tinted glass
- Wire-mesh boom walkway(for inner boom)
- Footrest
- Electric engine throttle control grip
- Engine throttle pedal
- Loud speaker
- Foot-pin cylinders
- Crawler connect cylinder
- Cat walk(no handrail, for rear cab)
- Planking(case for erect the boom)
- Rope guide roller on the boom back(for outer boom)

9. SPECIAL SPECIFICATIONS

(1) Additional Device

- 3rd hoisting winch(no free fall)
- Main/Auxiliary hoisting winch with free fall(with mode selector)
- Reeving winch combined use tagline
- Tagline
- Slewing parking break
- Slewing mode select switch(free/break)
- Drum rotation indication
- Monitor TV(for rear/drum view)
- Monitor TV(for hook/load)
- Mirror for drum
- Radio transmitter
- Combustion type heater
- Fire extinguisher
- Spark arrestor
- Operator cabin roof guard

(2) Light And Instrument

- Yellow rotary light
- Airplane warning light
- Boom point clearance lamp
- Over load outside alarm light(red/yellow/green)
- Work light for drum
- Work light on boom
- Hand light
- Back light
- Level
- Anemometer

(3) Step And Guard

- Handrail for cat walk
- Wire-mesh for boom walkway(for insert boom and outer boom)
- Safety guard on cab
- Safety guard rope on main boom

(4) Attachment

- 3m, 6m, 9m insert boom(with pendant rope and guide roller)
- taper insert boom of light boom and 3m , 6m insert jib(with tower)
- 13m basic jib and 6m insert jib(with pendant rope and guide roller)
- 3m, 6m, 9m Insert post boom and 3m, 6m, 9m insert jib
(with pendant rope and guide roller)
- 1m auxiliary jib
- 90 ton double hook block(four sheaves)
- 60 ton double hook block(three sheaves)
- 35 ton hook block(one sheave)
- 13.5 ton hook block
- Lifting peace for insert booms
- Rope guide roller on the boom back

(5) Name Plate

- Name plate(both side of base machine)
- Name plate(outer boom or both side of insert boom)

(6) Other

- Large size tool box(with caster)
- Sling wire rope(for lifting machine, attachment)
- Lifting pad for crawler